

# X-Leg Counter

## LN-CU-01

Dress up your space with sophisticated and functional counters. Counter tops are available in four thermoform finishes – silver, black, mahogany, and natural. Printed graphic panels create the base of the counter. Comes standard with a locking cabinet door. Custom counter top colors are available.

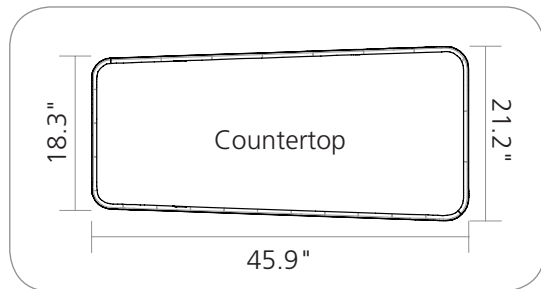

## features and benefits

- Custom appearance
- Easy to assemble
- Table top available in four finishes
- Locking door
- Internal shelf
- Installation tool included
- Aluminum frame construction
- Custom top and graphic colors available
- Legs can turn 90° for a different look
- Lifetime limited hardware warranty against manufacturer defects

## dimensions

### Hardware

Assembled Unit:  
45.9" w x 39.2" h x 21.2" d approx.  
1166mm(w) x 996mm(h) x 538mm(d)

Interior Cabinet Dimensions:  
22" w x 38" h x 12" d approx.  
559mm(w) x 965mm(h) x 305mm(d)

Tabletop Dimensions:  
45.9" w x 1" h x 21.2" d approx.  
1166mm(w) x 25mm(h) x 538mm(d)

### Shipping

Shipping dimensions - ships in 2 boxes:  
Each box: 48" l x 24" w x 4" h  
1219mm(l) x 610mm(w) x 102mm(h)

Approximate Shipping Weight: 52 lbs / 24 kgs

### Graphic

Total visual area:  
Cabinet Front:  
21.31" w x 35.8" h  
541mm(w) x 909mm(h)

Cabinet Back Door:  
17.53" w x 32.18" h  
445mm(w) x 817mm(h)

Cabinet Sides:  
11" w x 35.8" h  
279mm(w) x 909mm(h)

Refer to related graphic template for more information.

## additional information

Graphic Material:  
UV prints on 6mm sintra

Counter holds max 50 lbs / 23 kgs

Optional shipping case: OCH2

### Tabletop Colors:

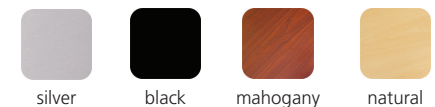

We are continually improving and modifying our product range and reserve the right to vary the specifications without prior notice. All dimensions and weights quoted are approximate and we accept no responsibility for variance. E&OE. See Graphic Templates for graphic bleed specifications.

Parts Included		
Part Label	Qty	Part code
VC-01	x4	?
VC-02	x1	CAB-01-FR
VC-03	x1	CAB-01-DR
VC-04	x1	CAB-01-SN-SD
Internal Shelf	x1	?
Shelf Support	x4	?
V-CU-CT-01	x1	?
VL-01	x1	V-LG-01
Front Graphic	x1	-
Back Graphic	x1	-
Side Graphic	x2	-
Tool kit	x1	V-TK-01

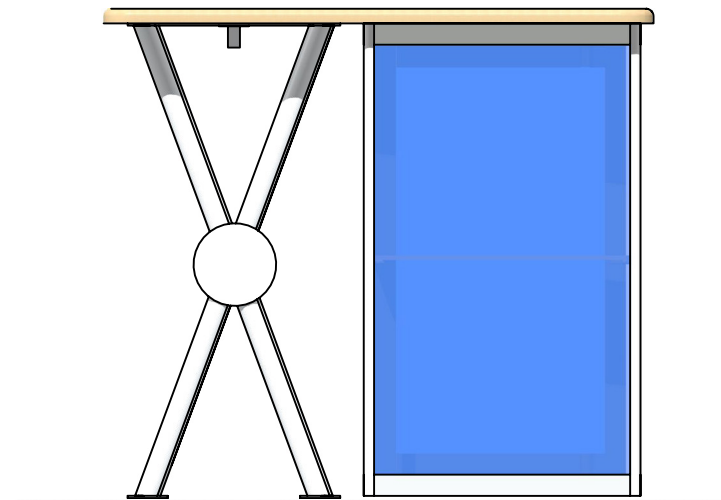
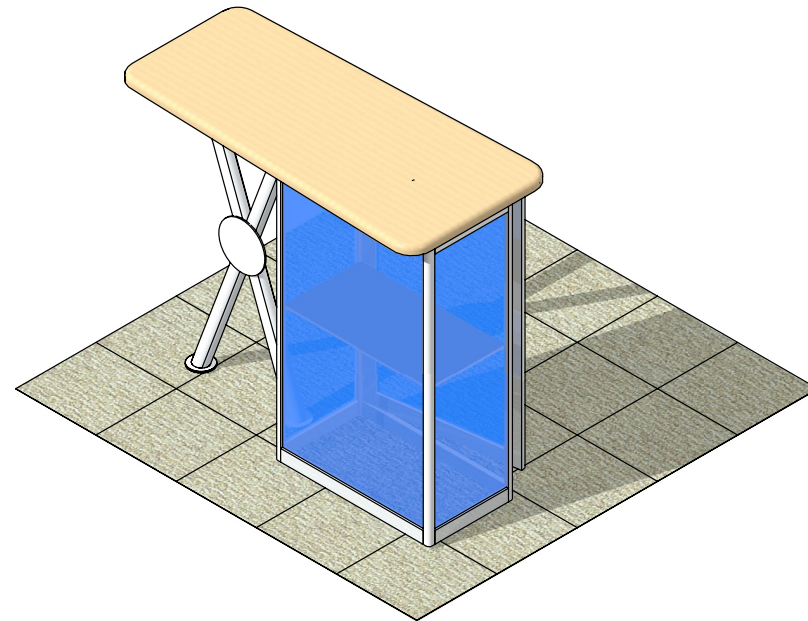

Step 1.  
Assemble counter frame and insert front and back graphics.

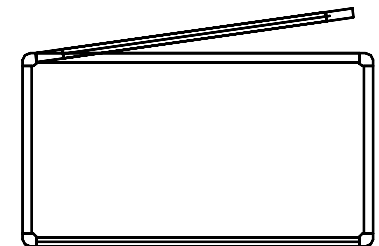
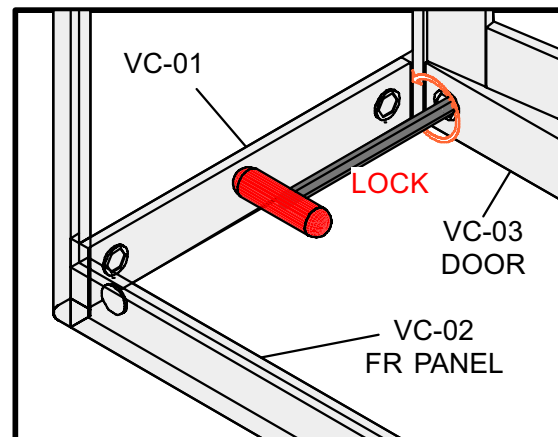
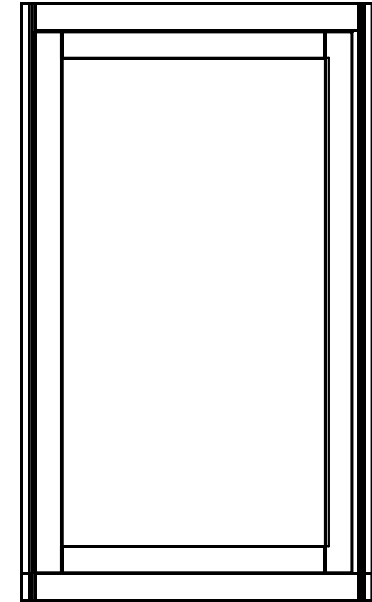
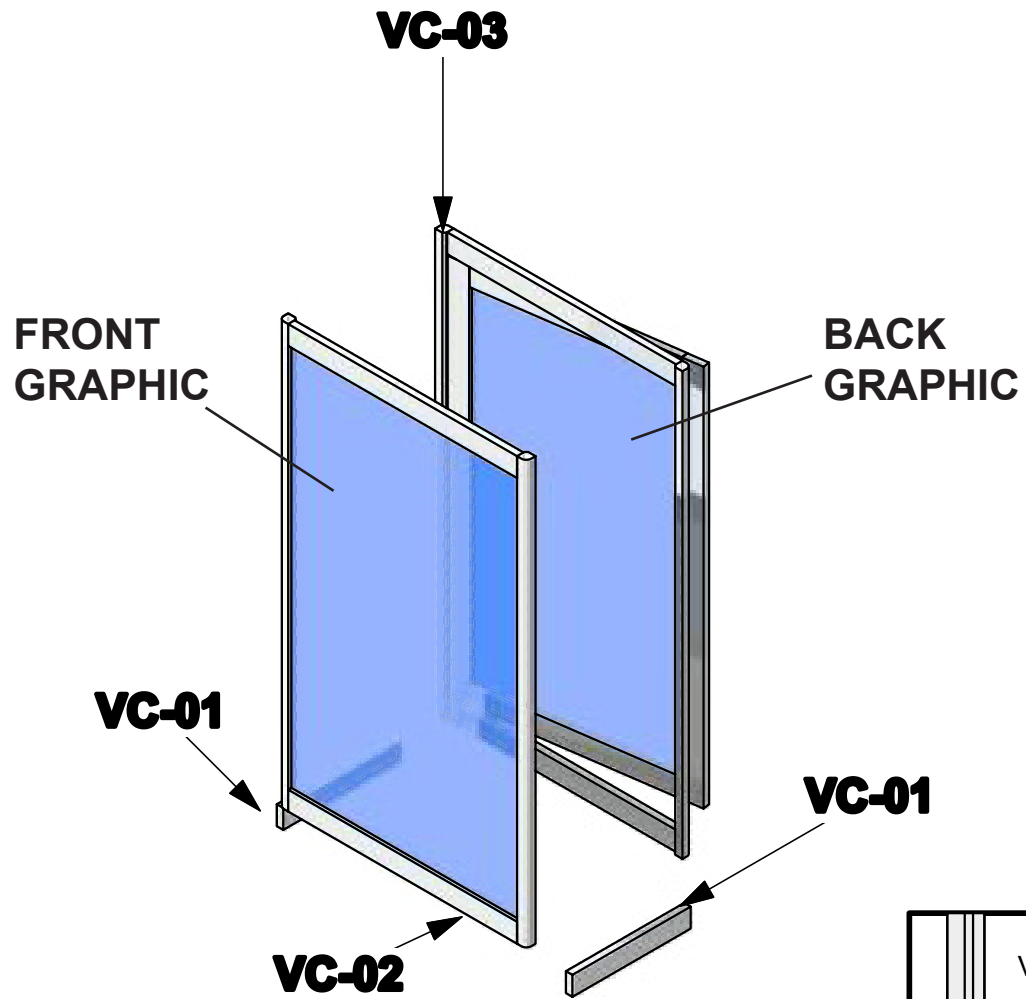

Step 2.

Add shelf and side panels. Continue to build frame upwards.

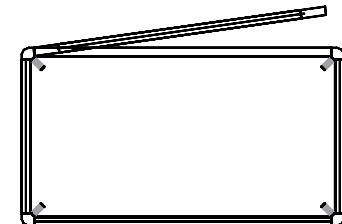
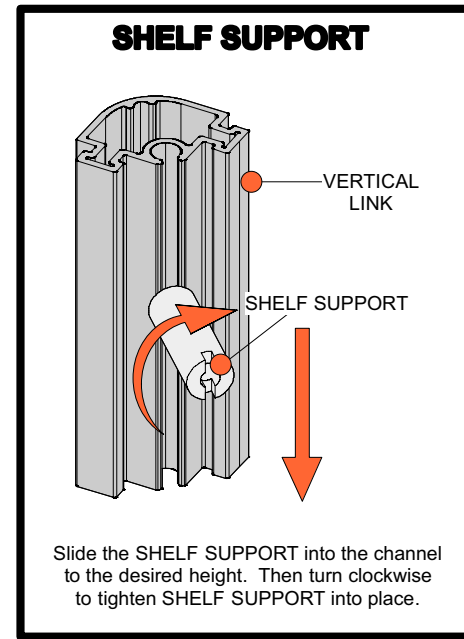
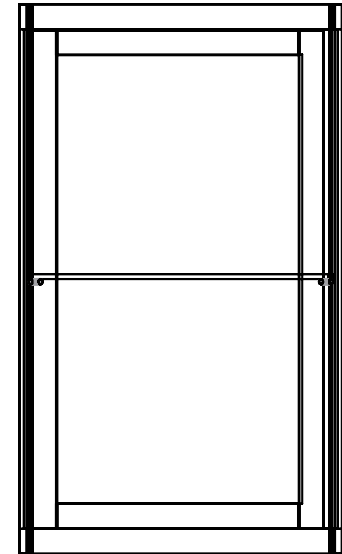
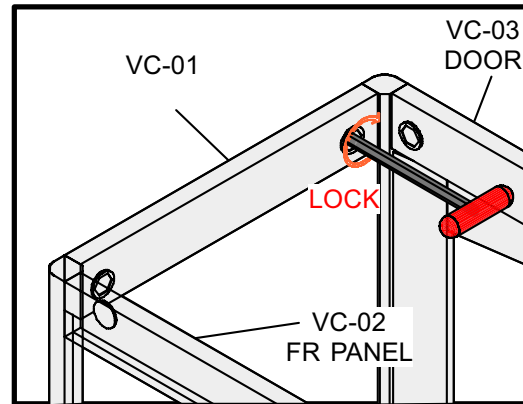
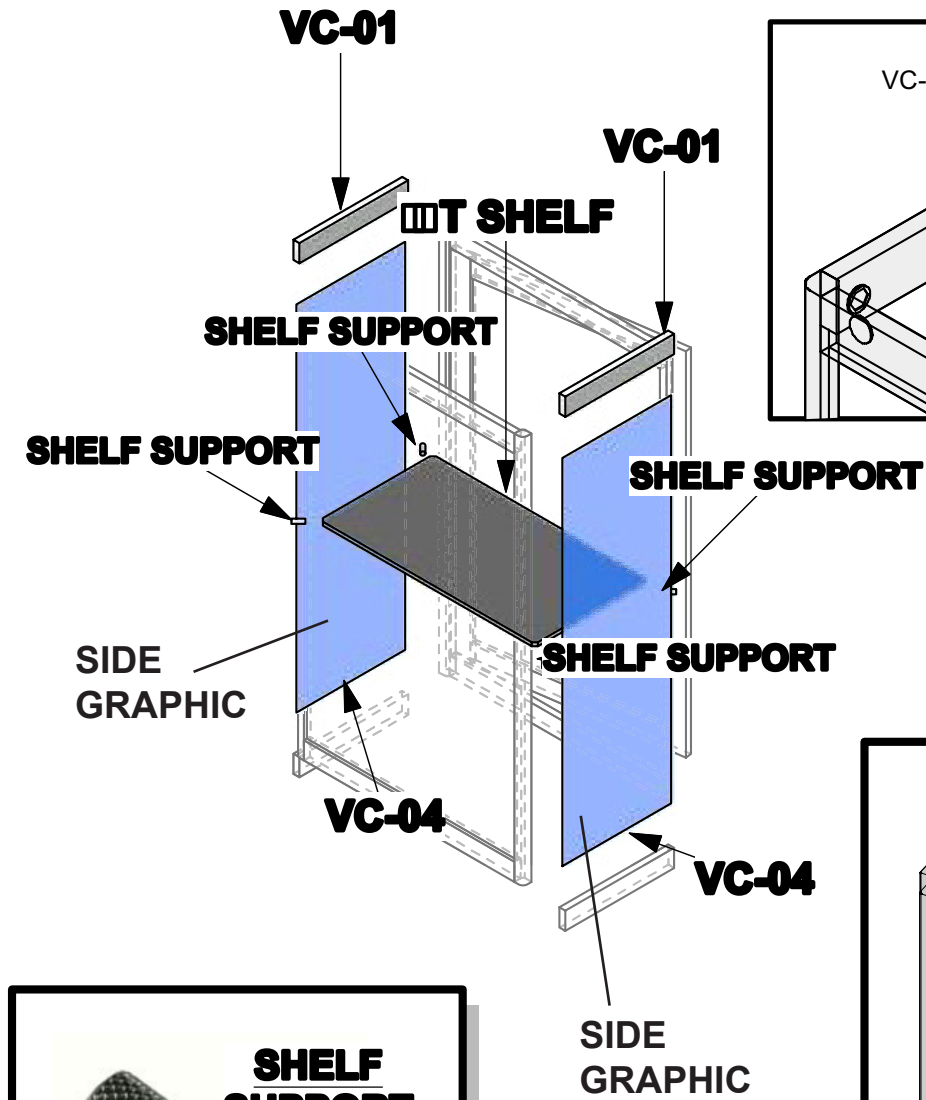

Step 3.  
Complete unit by attaching counter top.

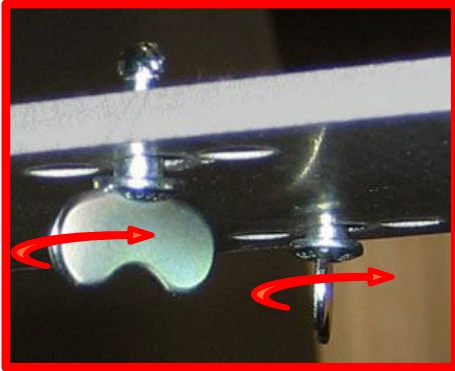

Insert the thumb connector into the bottom of the counter top and make a 1/4 turn clockwise to tighten in place.

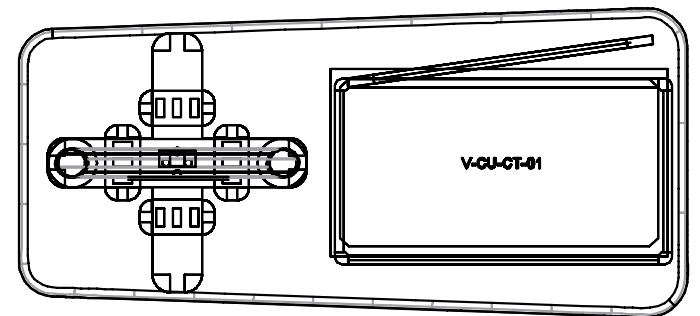
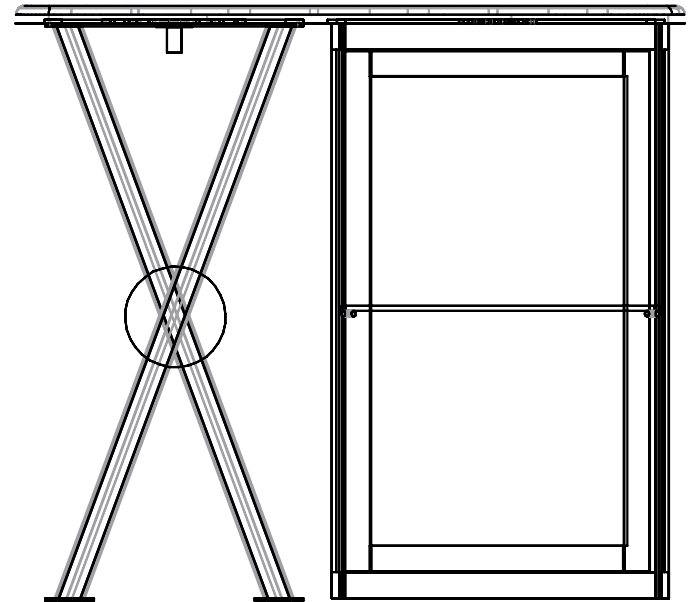
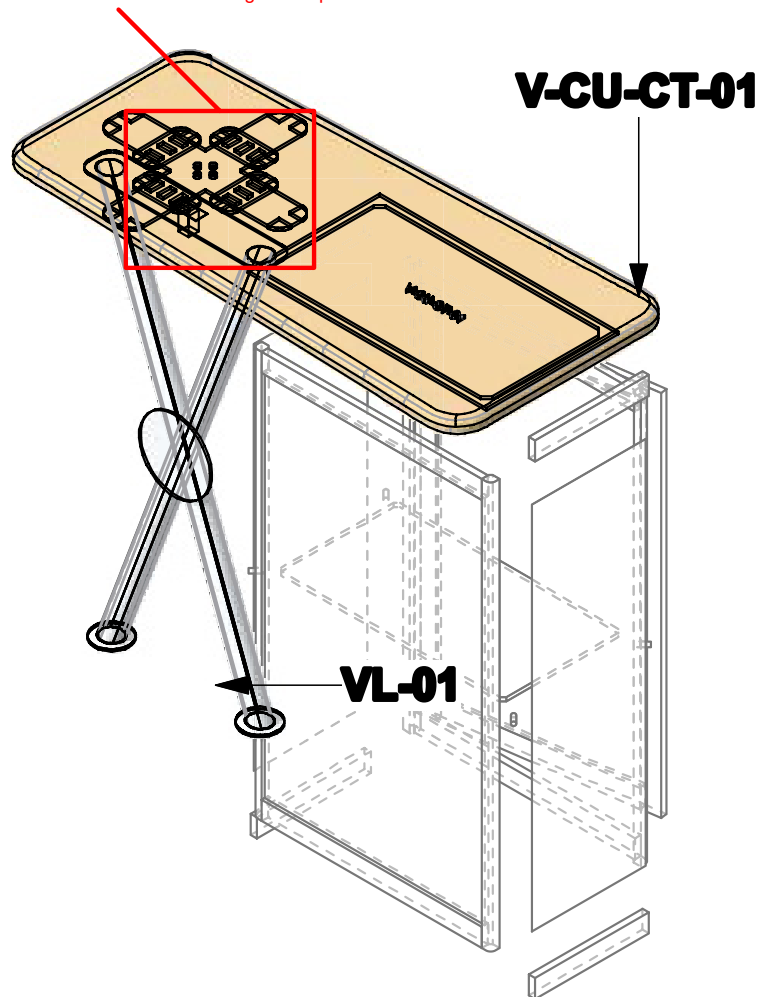

# Linear Counters

---



X-Leg Counter



V-Leg Counter



Tusk Leg Counter



Oval Counter

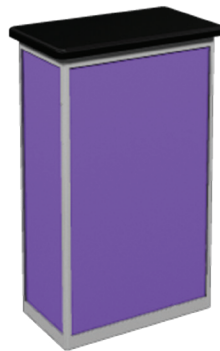

Counter - Rectangle



Straight Leg Counter



Double Reception Counter