

# Vector Frame Light Box S-02

## VF-LB-S-02

Vector Frame™ fabric light boxes feature durable 100mm aluminum extrusion frames, push-fit backlit fabric graphics and LED edge lighting. Single and double-sided graphic options are available. LED lights come adhered to the frame, making set-up as simple as assembling the frame, applying the push-fit graphics and plugging in the electrical cord!



## features and benefits

- 100mm silver extrusion frame
- LED lighting top and bottom
- Single or double-sided SEG dye-sublimated fabric graphics
- Easy assembly
- Comes packaged in one OCE wheeled molded case for transport or storage
- Lifetime hardware warranty against manufacturer defects

## dimensions

Hardware	Graphic
Assembled unit: 47.25" w x 47.25" h x 19.75" d 1200mm(w) x 1200mm(h) x 502mm(d)	Total visual area: 47.125" w x 47.125" h 1197mm(w) x 1197mm(h)  Refer to related graphic templates for more information
Shipping	
Shipping dimensions: 1 OCE case: 40" up to 66" l x 18" h x 18" d 1016 up to 1676mm(l) x 457mm(h) x 457mm(d)  Approximate shipping weight (entire kit): 55.99 lbs / 25.4 kgs	

## additional information

Graphic material:  
Dye-sublimated fabric

We are continually improving and modifying our product range and reserve the right to vary the specifications without prior notice. All dimensions and weights quoted are approximate and we accept no responsibility for variance. E&OE. See Graphic Templates for graphic bleed specifications.

Parts Included:

Code	Qty	Description
F25	x3	1200MM (47.25") LENGTH OF PHFC4 EXTRUSION - WITH MITRE CUT FOR CB9 BOTH SIDES
VF-LB-S-02-G	x2	1200MM (47.25")W X 1200MM (47.25")H FABRIC GRAPHIC W/FEC-2 ALL SIDES
LED-WHT-DB-300	x6	300MM (11.81") LENGTH LED LIGHTS FOR DIRECTIONAL BACKLIT
CB9	x4	CB9 CORNER BRACKET
SW-FOOT	x2	VECTOR FRAME SUPPORT FOOT
F59	x1	1200MM (47.25") LENGTH OF PHFC4 EXTRUSION - WITH MITRE CUT FOR CB9 BOTH SIDES - WITH WIRE HOLE
WME-150	x4	150MM (5.91") GREY RPVC WIRE MANAGEMENT EXTRUSION

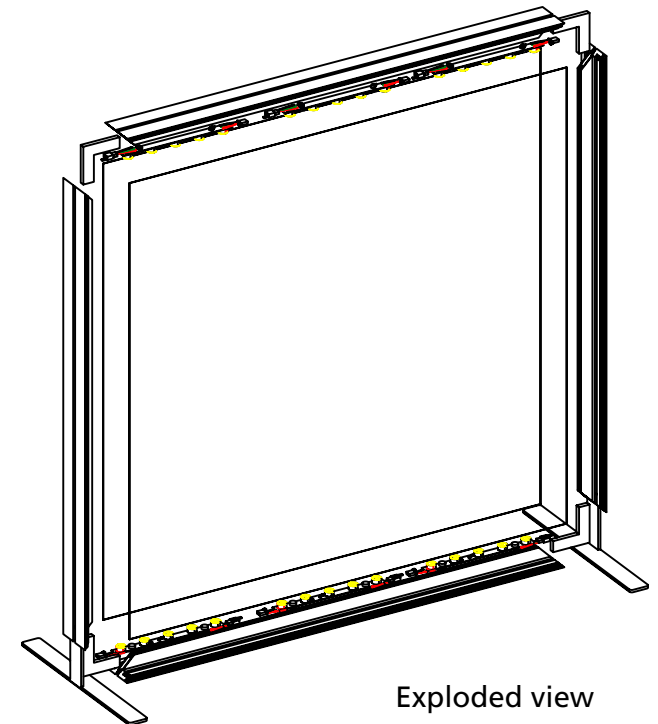
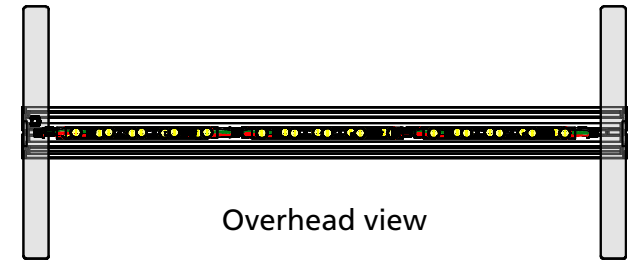
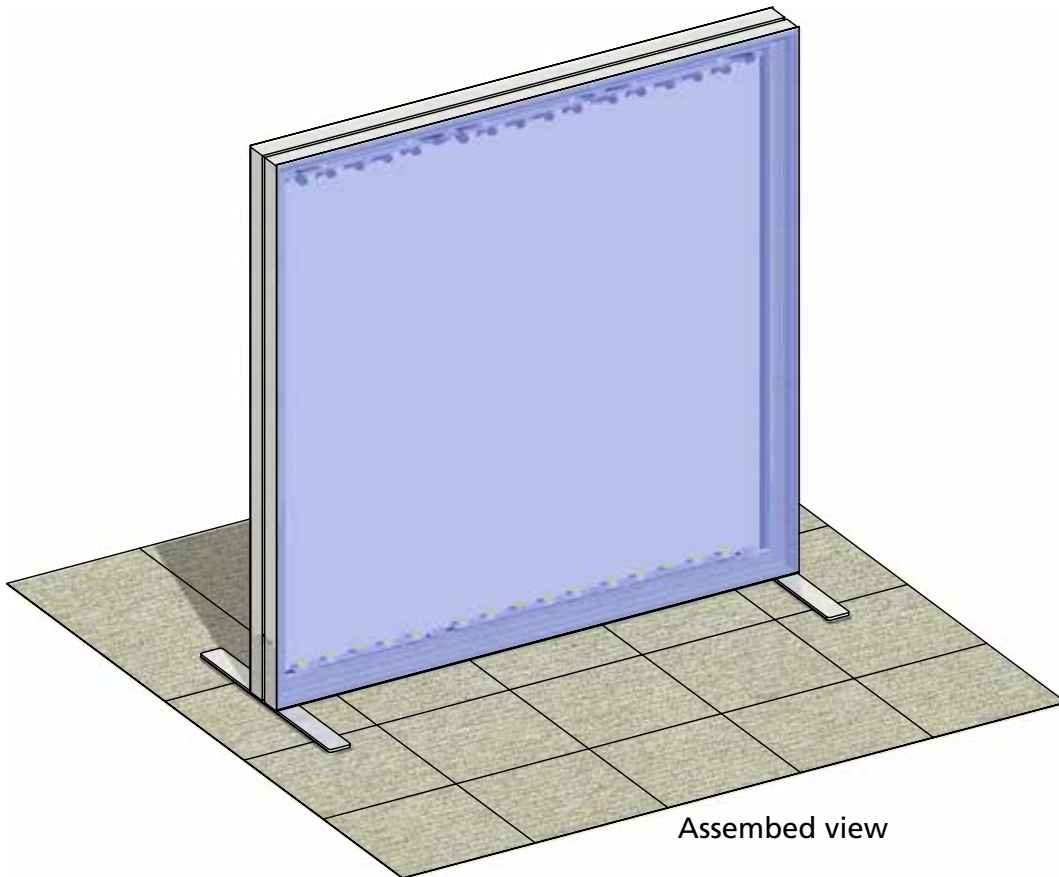

## Step 1: Assemble Frame

Arrange pieces on the floor as shown in the diagram below. Assemble frame by sliding CB9's into corners of the F25 and F59. Lights come adhered to the F25s. Ensure lighting strips are connected. When locking be sure to turn each cam a little bit and then go back and tighten to the proper tension. Take care to turn locks only half a turn.

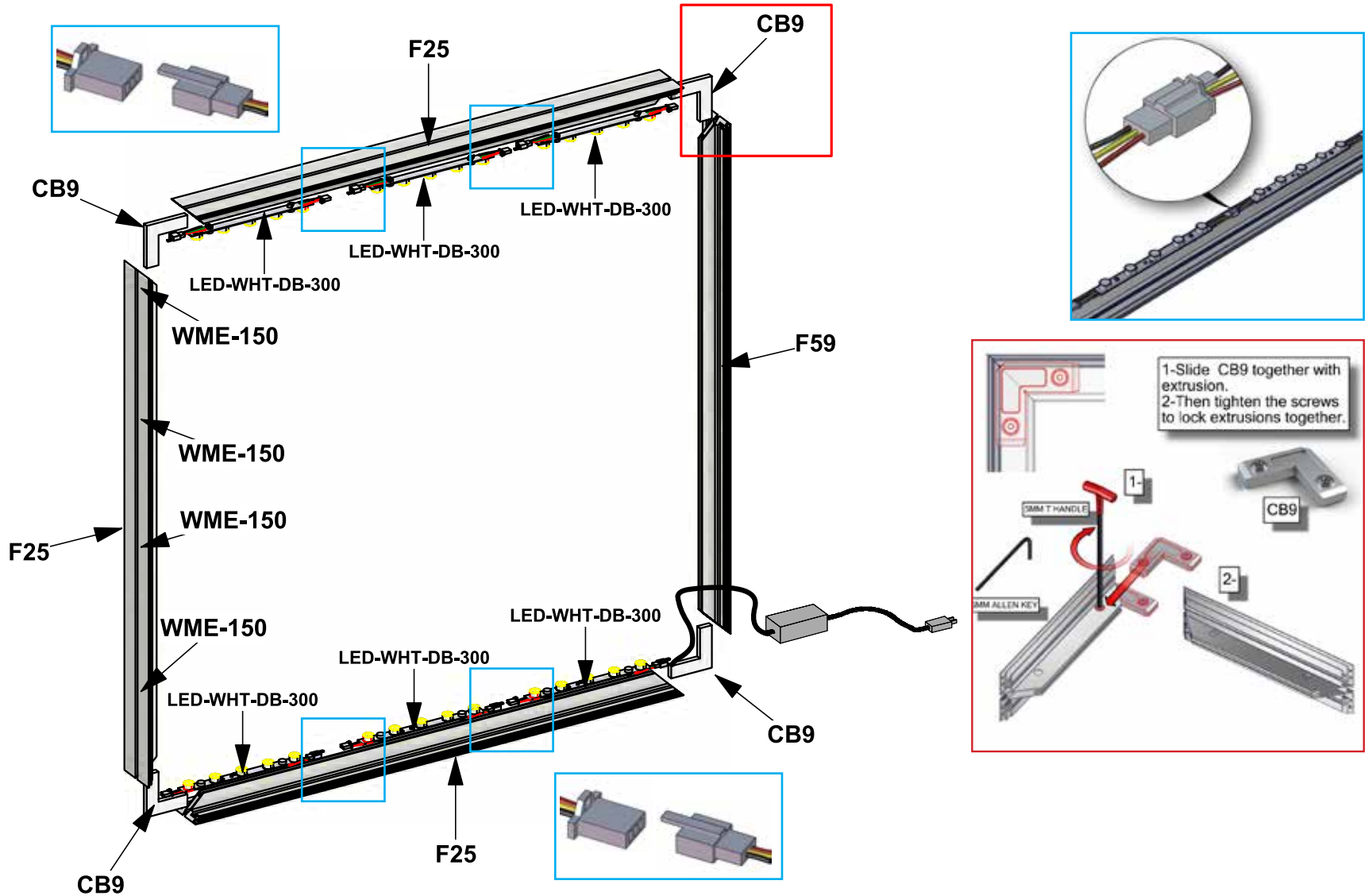

## Step 2: Attach Light Strips with Wire Management

Once frame is assembled and lighting strips are connected, connect black wire LED-DB-LC-300 to lighting strips on top and bottom. Run cords with wire management extrusion (WME). Place LED-DB-LC-300 into plastic wire management strip and insert into F25 extrusion. Next, run LED-DB-CL-DCJ-600 cord through wire hole at the bottom right end of vertical extrusion then connect to lighting strip. Connect to power supply. Important: 9 lighting strips maximum per power supply.

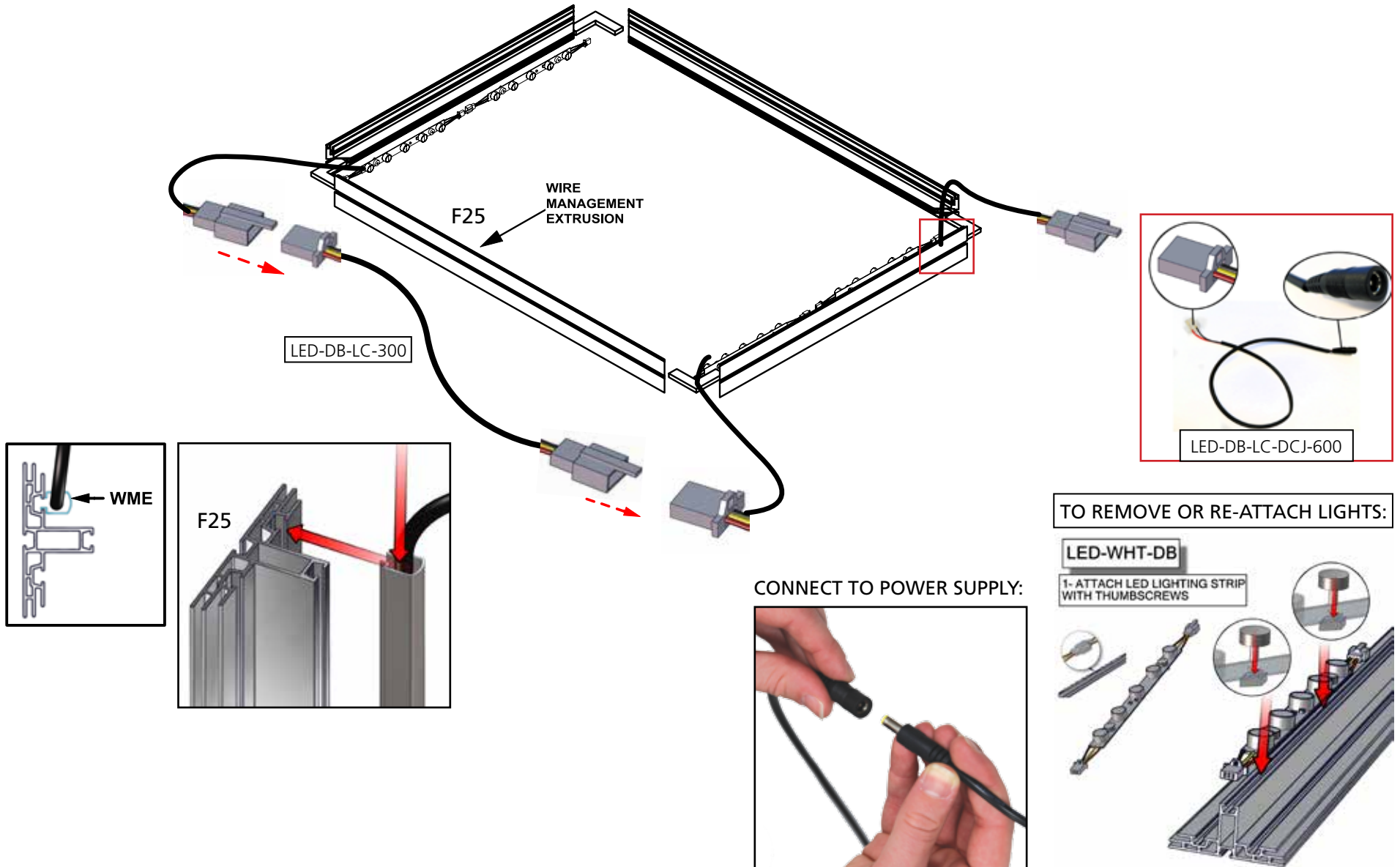

## Step 2: Attach feet to frame & apply graphics

To adhere foot to frame, loosen thumbscrews from foot. Slide extrusion into LN-100 groove. Gently tighten the foot into place. Install graphics by pressing the FCE-2 edge of graphic into the channel of the extrusion. Printed fabric graphic should be placed in outside channel(s). Liner for single-sided light boxes is placed in inside channel. Start in upper left corner, go across the top and then down the sides to the bottom. Assume each graphic is tightly inserted. When taking graphics off, take care to gently pull by attached pull tab. Set frame aside.

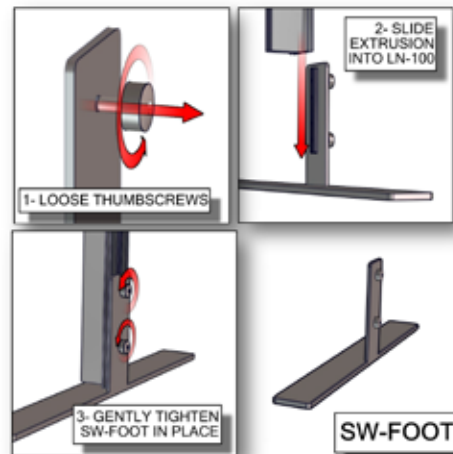
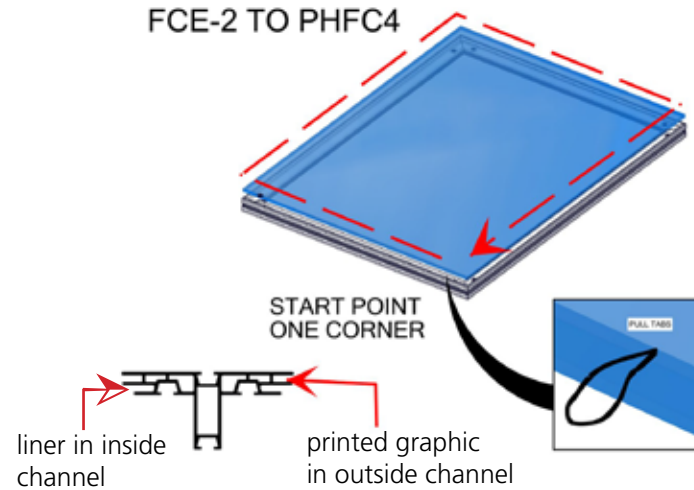
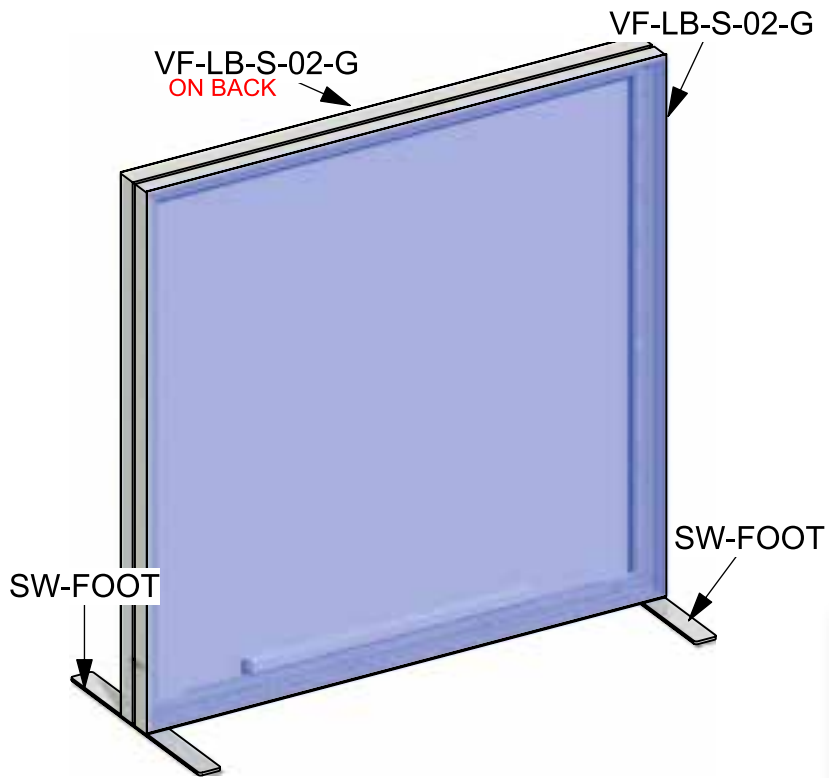

1- Slide light clip onto the LIGHT.  
2- Then slide the LIGHT into the channel at an angle and then gently lower down.

**OPTIONAL**

