

Linear Kiosk 01

LN-K-01

Dress up and add wow to your space with state-of-the-art multimedia kiosks.



We are continually improving and modifying our product range and reserve the right to vary the specifications without prior notice. All dimensions and weights quoted are approximate and we accept no responsibility for variance. E&OE. See Graphic Templates for graphic bleed specifications.

features and benefits:

- Custom appearance
- Easy to assemble
- Top available in four finishes
- Aluminum construction: vertical extrusions 50mm x 50mm
- Lockable counter with internal shelf
- Wings are double sided
- Installation tool included
- Kit includes one OCH2 case, custom printed canopy with pillowcase graphic, rigid custom printed graphics, custom printed counter infills, and monitor mount
- Easy step-by-step instructions
- Lifetime hardware warranty against manufacturer defects

dimensions:

Hardware	Graphic
<p>Assembled unit: 54.4" w x 99" h x 23.25" d approx. 1381.8mm(w) x 2514.6mm(h) x 590.55mm(d)</p> <p>Locking counter: 23.1" w x 39.4" h x 12.8" d approx. 586mm(w) x 1000.8mm(h) x 325.12mm(d)</p> <p>Internal shelf: 21.7" w x 18.1" d approx. 550.6mm(w) x 458.6mm(d)</p>	<p>Side wings: Total visible area: 11.25" w x 42.32" h 285.75mm(w) x 1074.9mm(h)</p> <p>Pillowcase canopy graphic: Total visible area: 55.2" w x 23.25" d 1402.08mm(w) x 590.55mm(d)</p> <p>Cabinet graphic, backside: Total visible area: 21.31" w x 35.8" h 541.3mm(w) x 909.3mm(h)</p>
<p>Shipping</p> <p>Shipping dimensions - ships in one case OCH2 case: 52" l x 30" w x 15" h 1320.8mm(l) x 762mm(w) x 381mm(h)</p> <p>Approximate shipping weight: 125lbs/56.7kg</p>	<p>Cabinet graphic, left & right sides: Total visible area: 7.84" w x 35.8" h 199.136mm(w) x 909.32mm(h)</p> <p>Cabinet graphic, front door: Total visible area: 17.53" w x 32.18" h 445.262mm(w) x 817.372mm(h)</p> <p>Refer to related graphic template for more information</p>

additional information:

Graphic materials:
Dye-sublimated fabric & UV prints on 6mm sintra

Tabletop color options:



silver



black



mahogany



natural

Counter holds max weight 100lbs/45.4kg

Monitor mount holds max weight
50lbs/22.7kg

Wings can be upgraded to frosted plex

Parts Included					
Part label	Qty	Part code	Part label	Qty	Part code
VC-02 (back graphic)	x1	V-CAB-01-FR-01	Monitor mount	x1	MM-MB
VC-03 (front graphic)	x1	V-CAB-01-DR	Standoff	x4	CKAPS
VE-32	x8	PH-200-S-S	Canopy	x1	V-K-CAN-01
VE-33	x1	PS2-521-L-L	Shelf support	x4	SS1-S
VE-35	x1	WME-600	Joining bar	x4	LN100
VE-36	x4	PM2R8-1200-A-A	T-Handle	x1	T-HANDLE
VE-45	x2	PH4-300			
VE-46	x2	PH4-75-L			
Graphic A (canopy)	x1	-			
Wing B	x1	-			
Wing C	x1	-			
Graphic D (side)	x1	-			
Graphic E (side)	x1	-			
Graphic F (side)	x1	-			
Graphic G (side)	x1	-			
Internal shelf	x1	V-CU-CAB-020S			
V-K-CT-01	x1	V-K-CT-01			

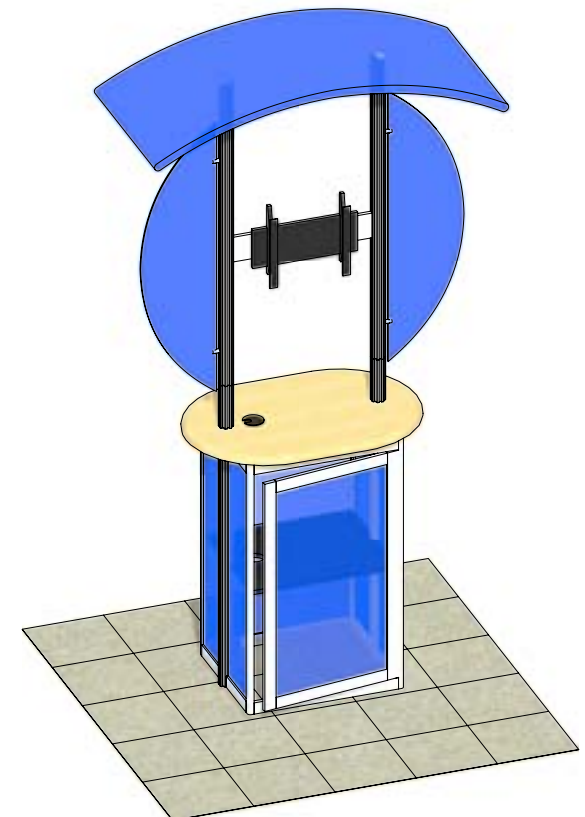
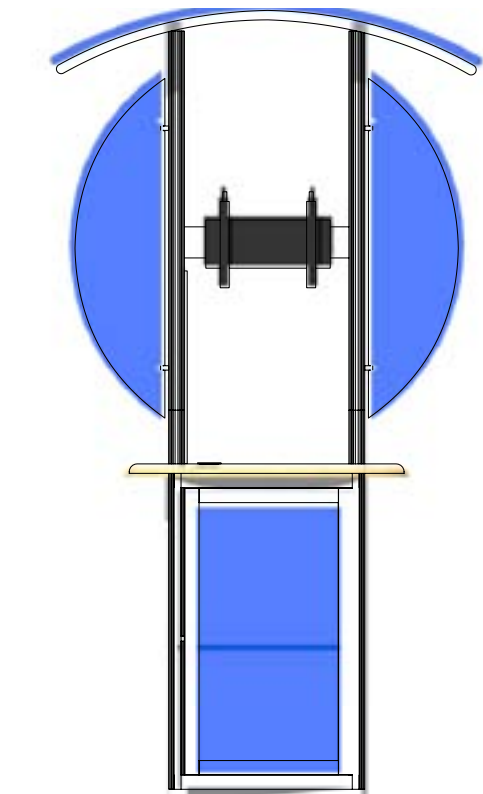
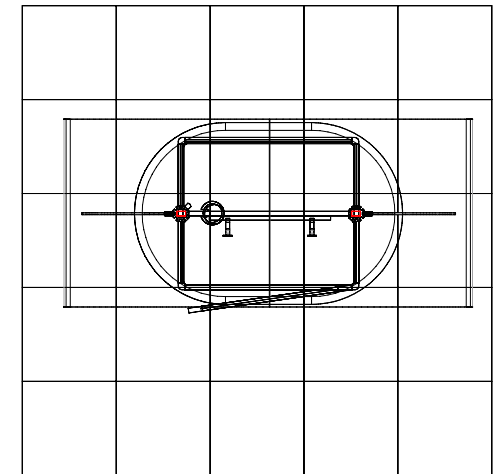

Step 1.

Lock VE-32's to door and back panel using detail below.

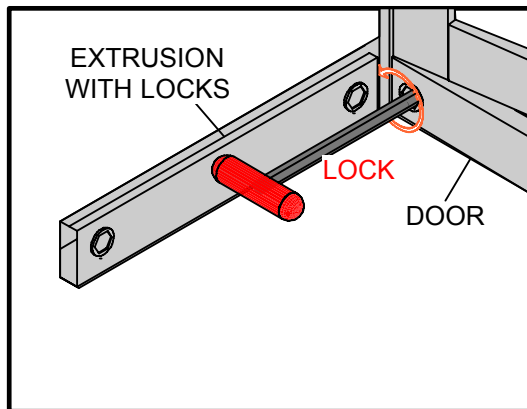
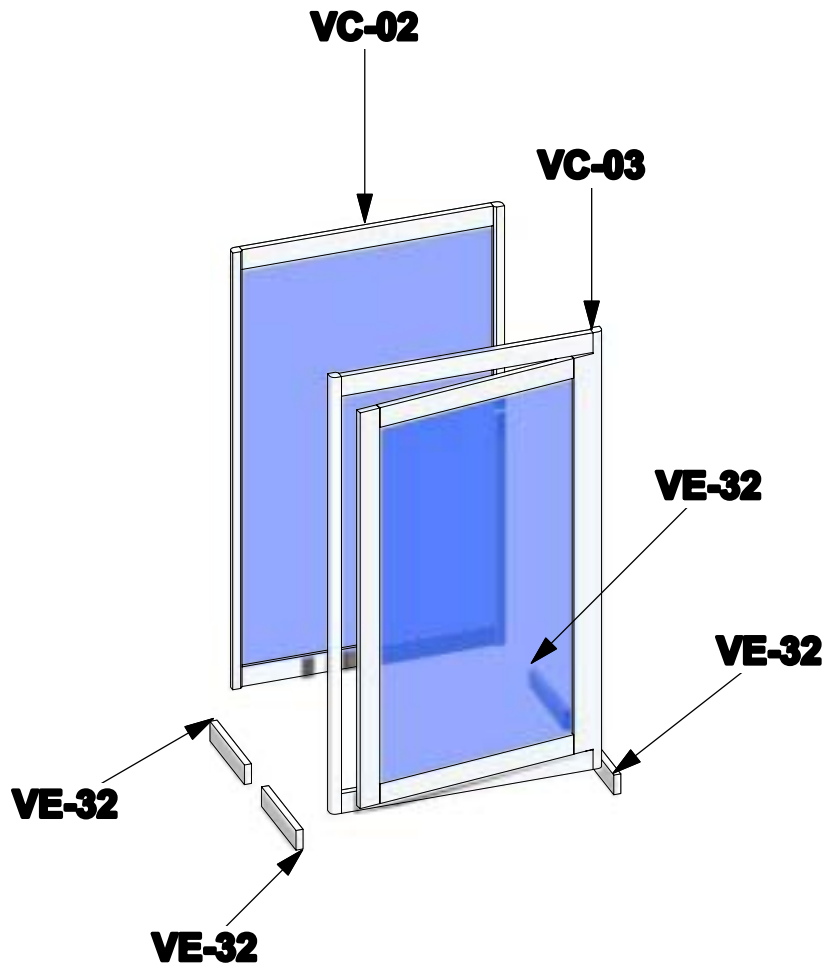

Step 2.

Lock left and right VE-36 posts to bottom VE-32s using detail below.
Slide VE-45s into VE-36s.

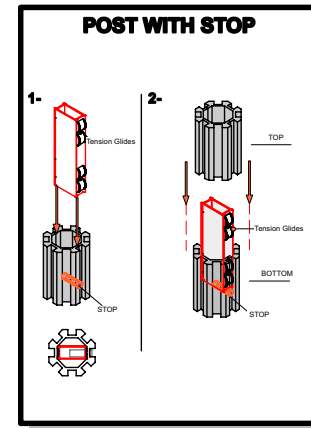
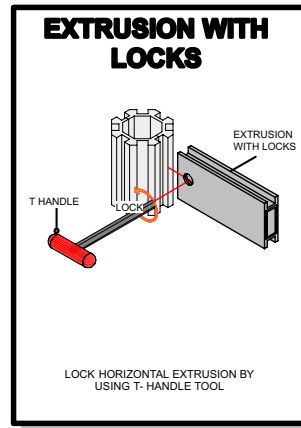
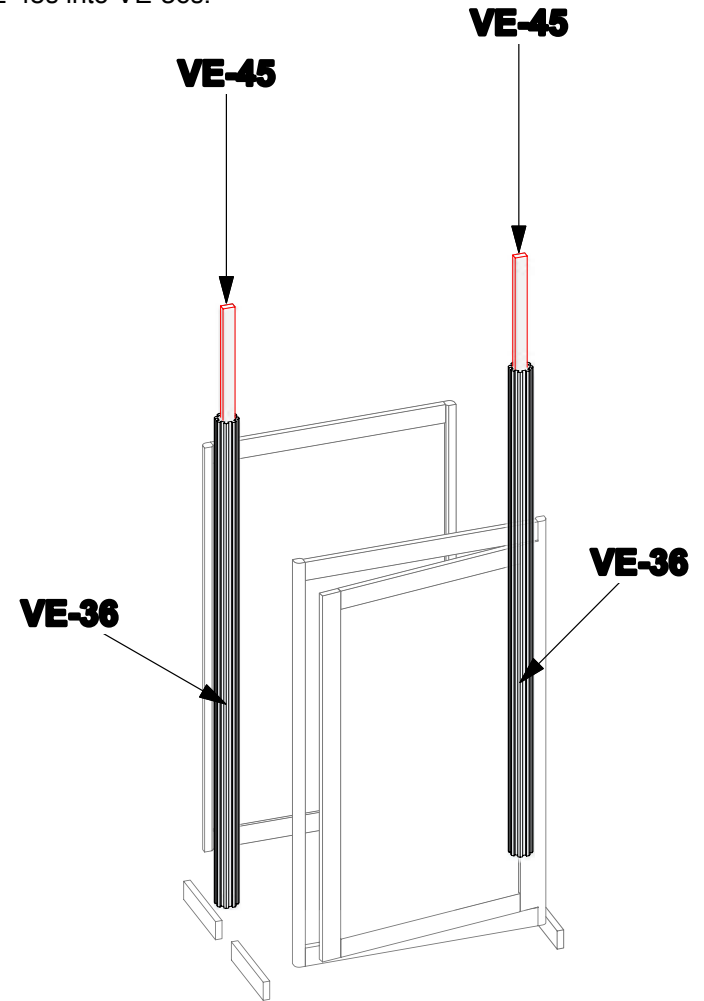

Step 3.
 Slide side graphics into channels of bottom VE-32s. Lock top VE-32s into place to capture graphics using detail below. Note that upper VE-32s should be flush at top with door and back panel.

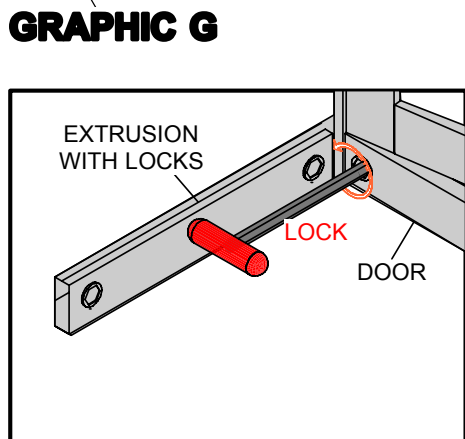
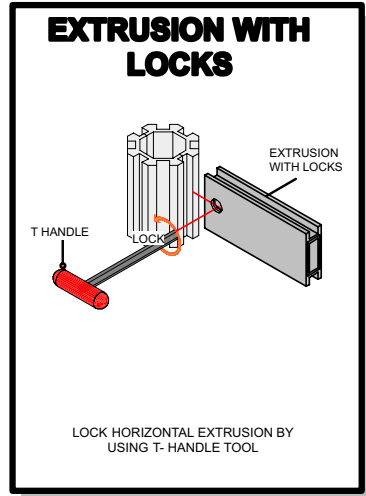
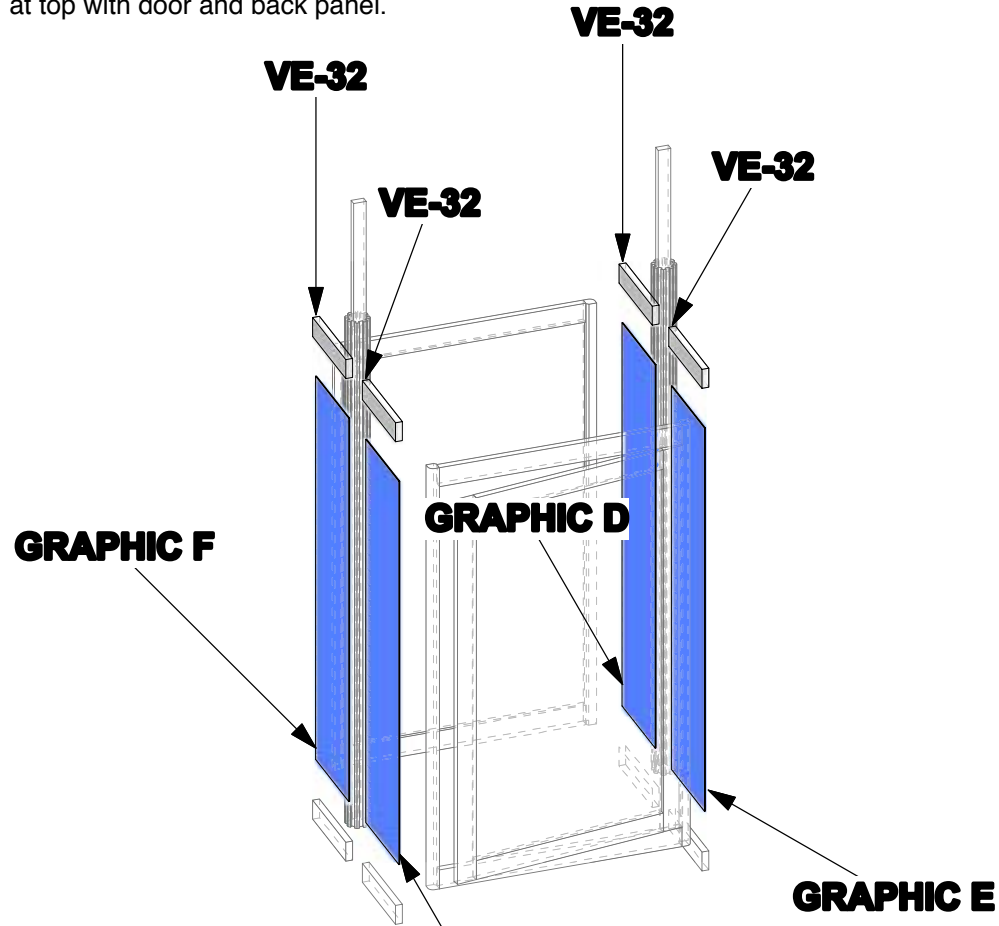

Step 4.
 Add shelf supports at desired height using detail below. Gently place internal shelf on supports. Slide countertop over VE-36 lower verticals. Slide the upper VE-36s over the VE-45 internal supports and attach the joining bars as detailed below.

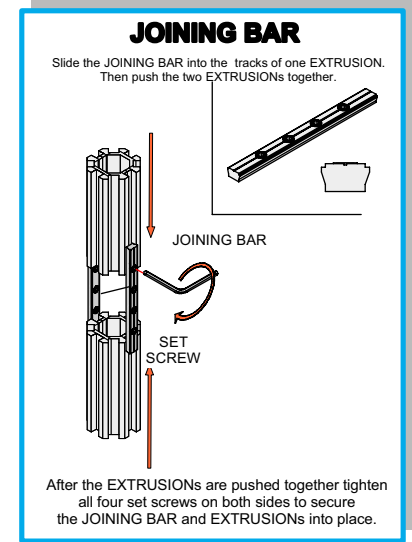
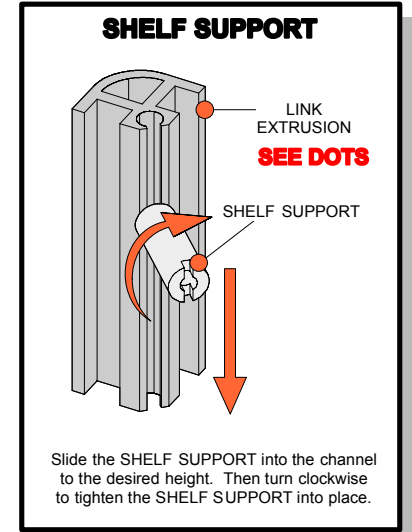
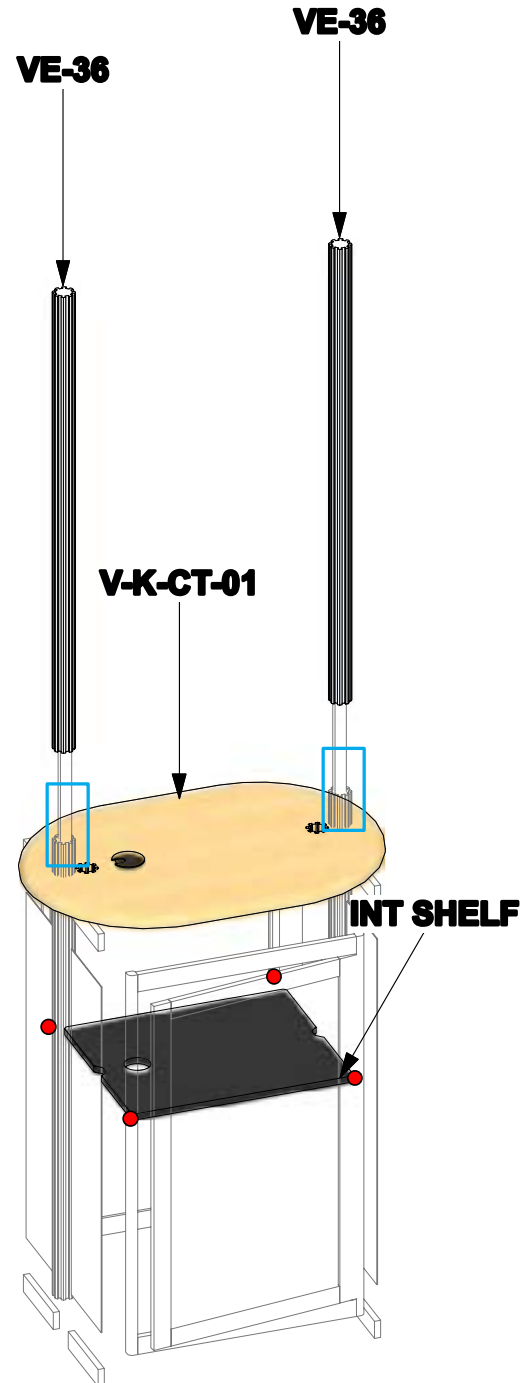

Step 5.
Lock monitor mount into VE-36s using attachment detailed below. Run cable through VE-35 and snap into channel on grommet side.

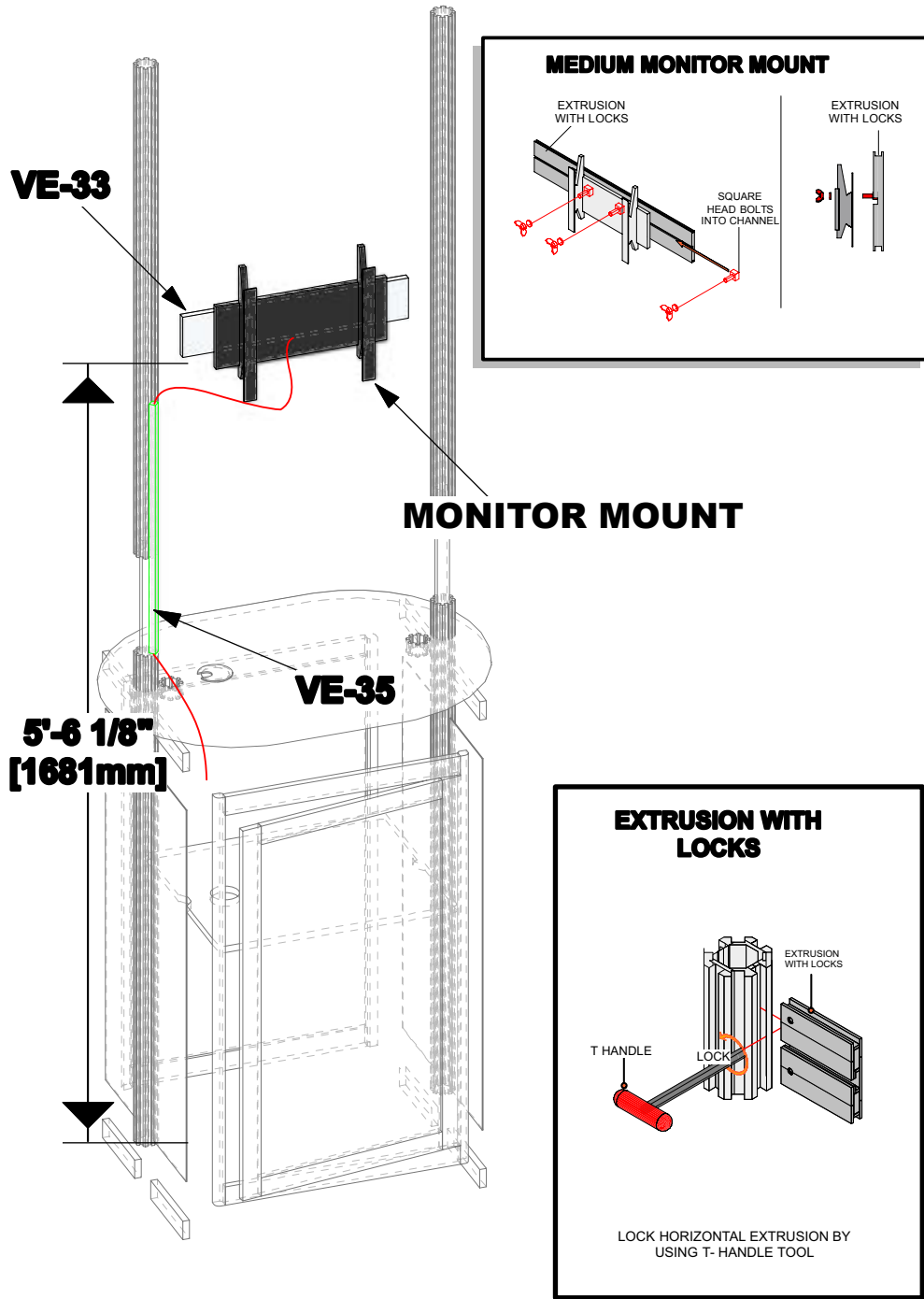

Step 6.
Attach standoffs to VE-36s using attachment detailed below. Attach wings to standoffs.

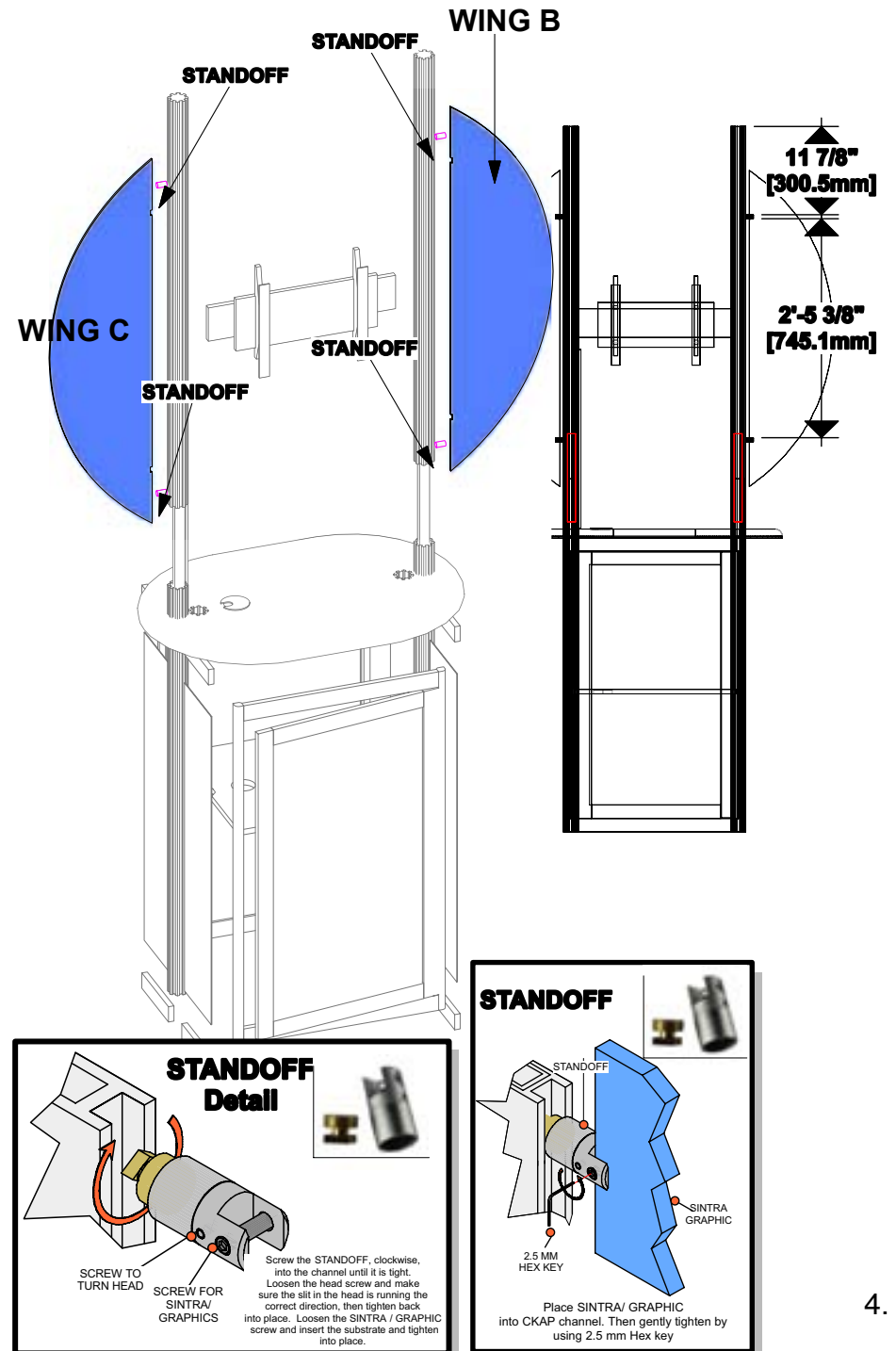

Step 7.

Assemble the canopy by connecting the pieces following the numbered labels. Clean the frame and place it on a clean surface. Carefully remove the graphic and place it around the bottom of the frame, slits on the underside of the graphic. Pull the cover carefully over the frame and close all zippers. When breaking system down, be sure to fold or roll the graphic neatly and place in bag.

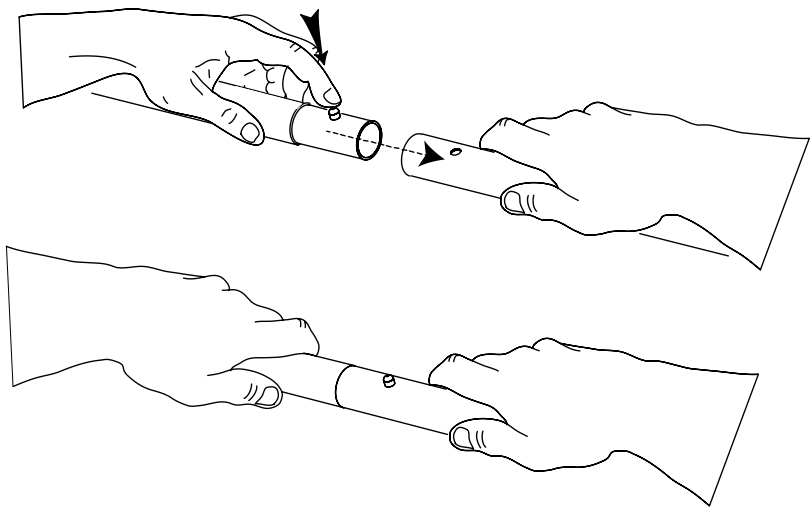
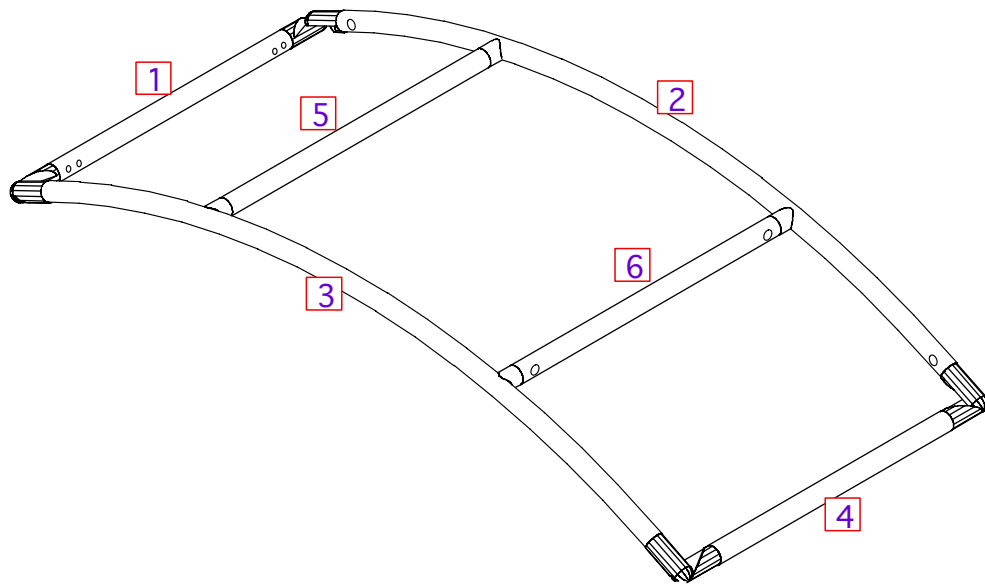

Step 8.

Lock VE-46s to canopy through slits in graphic. Attach completed canopy by sliding the VE-46 into the vertical posts.

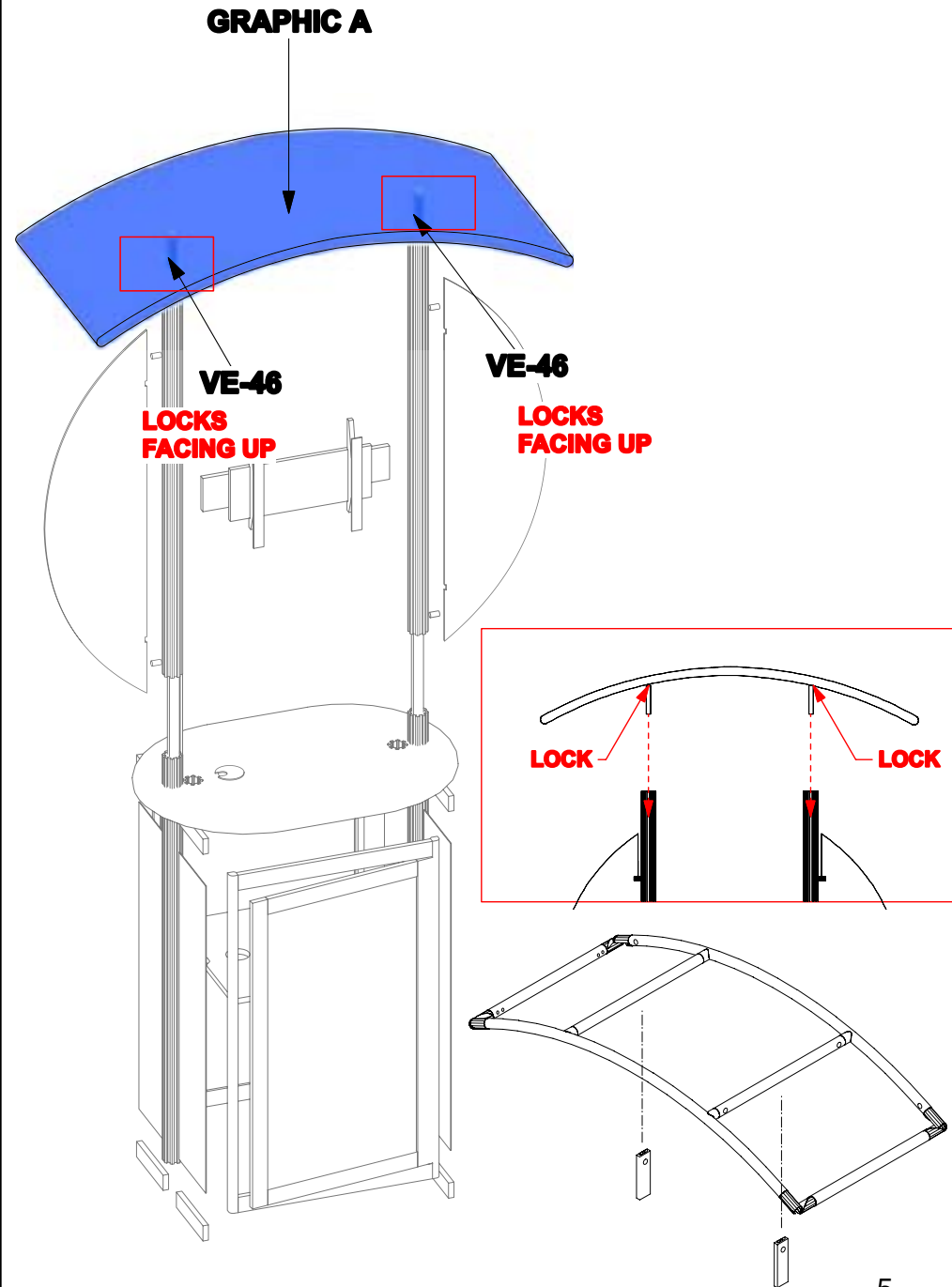

Check out these related products:



Linear Kiosk 01



Linear Kiosk 02



Linear Kiosk 03



Linear Kiosk 04
