

Lumina 200

This is a 110 volt ETL approved wall washer floodlight with a straight arm and an adjustable head. The light includes a 200 watt halogen bulb or LED bulb. It has a silk black finish.



Important Facts and Safety Procedures

Tungsten Halogen
130 Volt
200 Watts
T3

Important Safety Instructions: 8800-6-3

Read all instructions

WARNING! To reduce the risk of fire, electric shock or injury to persons:

- Minimum distance to lighted object: 16 inches (.5 mm)
- Input: 120V, 60 Hz
- CAUTION: Risk of fire - Use 200 watt or smaller double ended halogen lamp type T-3, 120 volt
- CAUTION: To reduce the risk of a burn during replacing bulb, disconnect power to the unit by unplugging before bulb replacement
- Keep fixture away from combustible materials
- Replace cracked protective shield immediately. Do not use fixture without the shield being installed
- To reduce the risk of exposure to excessive UV radiation, do not remain under light if skin feels warm
- Protect the fixture from impact, scratching or abrasions
- If the cord-set becomes damaged, replace the cord-set before using fixture

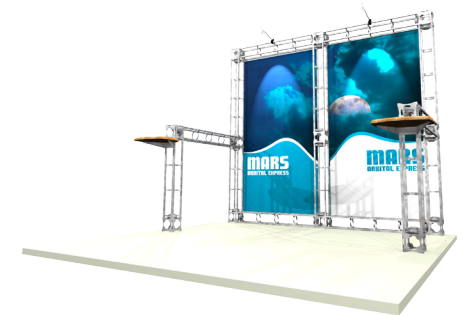

We are continually improving and modifying our product range and reserve the right to vary the specifications without prior notice. All dimensions and weights quoted are approximate and we accept no responsibility for variance. E&OE. See Graphic Templates for graphic bleed specifications.

To Remove Lamp:

1. Turn off/unplug fixture and allow to cool before replacing lamp. Lamp gets hot quickly. Do not touch hot lamp or shade.
2. Remove the protective shield.
3. Push the lamp towards one end of the lamp-holder which serves as a spring to hold lamp in place. When the other end of the lamp is clear of the holder, lift the lamp out of fixture.

To Fit or Replace Lamp:

1. Take the lamp out of the box taking care not to touch the lamp with your bare fingers. Oil from skin can damage lamp. Use a soft cloth when grasping lamp. Grasp the lamp with the thin wrapper covering and place one end of the bulb against the spring section of the lamp-holder and push it toward the spring side. ATTENTION: Insert lamp in the neutral lamp-holder first (see marking on fixture.)
2. As the other end of the lamp clears the opposite end of the lamp-holder, insert the end down into the lamp-holder and release the tension on the spring end. Both ends of the lamp must come in contact with both ends of the lamp-holder.
3. IMPORTANT: Reinstall protective shield after changing lamp.

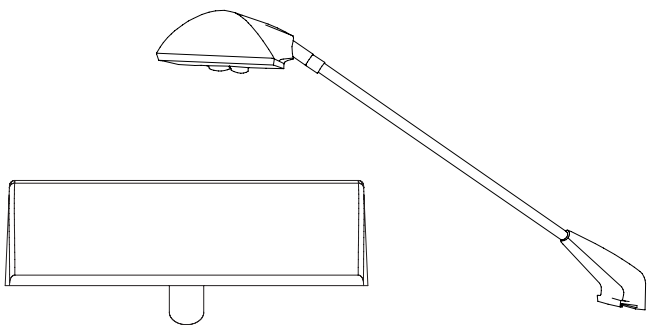

Supplied with light:



UNIVERSAL LIGHT CLAMP KIT

UNI-LT-CLP

- comes standard with the Lumina 1, 3, 4, 5, 6, 8, 9, 10, 11, 12, 13, 200 and allows our lights to fit a majority of banners, truss & panel kits

Optional:

LUMINA SPT CASE



SPT-CASE

- EVA semi-rigid lighting case
- foam-lined padded compartments
- holds two Lumina lights & power supply



LUMINA 200 LED

LUM-LED-ORL-B

- LED version of the Lumina 200 floodlight
- 1400 Ma, 12 VDC
- LED rated for 20,000 continuous hours