

Double Reception Counter

LN-CU-05

Dress up your space with sophisticated and functional counters. Counter tops are available in four thermoform finishes – silver, black, mahogany, and natural. Printed graphic panels create the base of the counter. Comes standard with a locking cabinet door. Custom counter top colors are available.

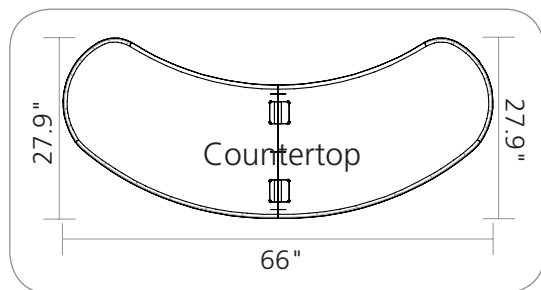

features and benefits

- Custom appearance
- Easy to assemble
- Table top available in four finishes
- Locking door
- Internal shelf
- Installation tool included
- Aluminum frame construction
- Custom top and graphic colors available
- Legs can turn 90° for a different look
- Lifetime limited hardware warranty against manufacturer defects

dimensions

Hardware	Graphic
<p>Assembled Unit: 66" w x 39.2" h x 27.9" d approx. 1676mm(w) x 996mm(h) x 708mm(d)</p> <p>Interior Cabinet Dimensions: 22" w x 38" h x 12" d approx. 559mm(w) x 965mm(h) x 305mm(d)</p> <p>Tabletop Dimensions: 66" w x 1" h x 27.9" d approx. 1676mm(w) x 25mm(h) x 708mm(d)</p>	<p>Total visual area: Cabinet Front: 21.31" w x 35.8" h 540mm(w) x 900mm(h)</p> <p>Cabinet Back Door: 17.53" w x 32.18" h 450mm(w) x 800mm(h)</p> <p>Cabinet Sides: 11" w x 35.8" h 300mm(w) x 900mm(h)</p>
<p>Shipping</p> <p>Shipping dimensions - ships in 2 boxes: Each box: 48" l x 24" w x 4" h 1219mm(l) x 610mm(w) x 102mm(h)</p> <p>Approximate shipping weight: 86 lbs / 39 kgs</p>	<p>Refer to related graphic template for more information.</p>

additional information

Graphic Material:
UV prints on 6mm sintra

Counter holds max 100 lbs / 45.4 kg

Optional Shipping Case: OCH2

Tabletop Colors:

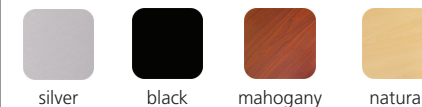

We are continually improving and modifying our product range and reserve the right to vary the specifications without prior notice. All dimensions and weights quoted are approximate and we accept no responsibility for variance. E&OE. See Graphic Templates for graphic bleed specifications.

Parts Included		
Part Label	Qty	Part code
VC-01	x8	PH-280-S-S
VC-02	x2	CAB-01-FR
VC-03	x2	CAB-01-DR
VC-04	x4	CAB-01-SN-SD
Cabinet Front	x2	-
Cabinet Back	x2	-
Cabinet Side	x4	-
Internal Shelf	x2	-
V-CU-CT-01	x2	V-CU-CT-01
Tool kit	x1	V-TK-01

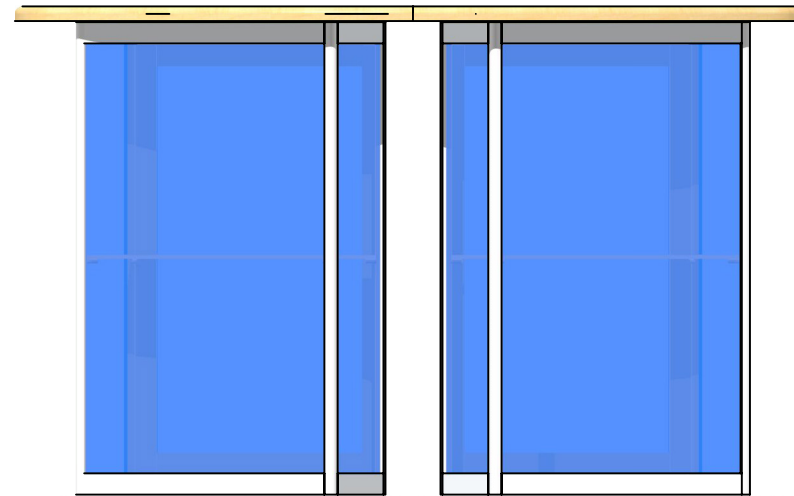
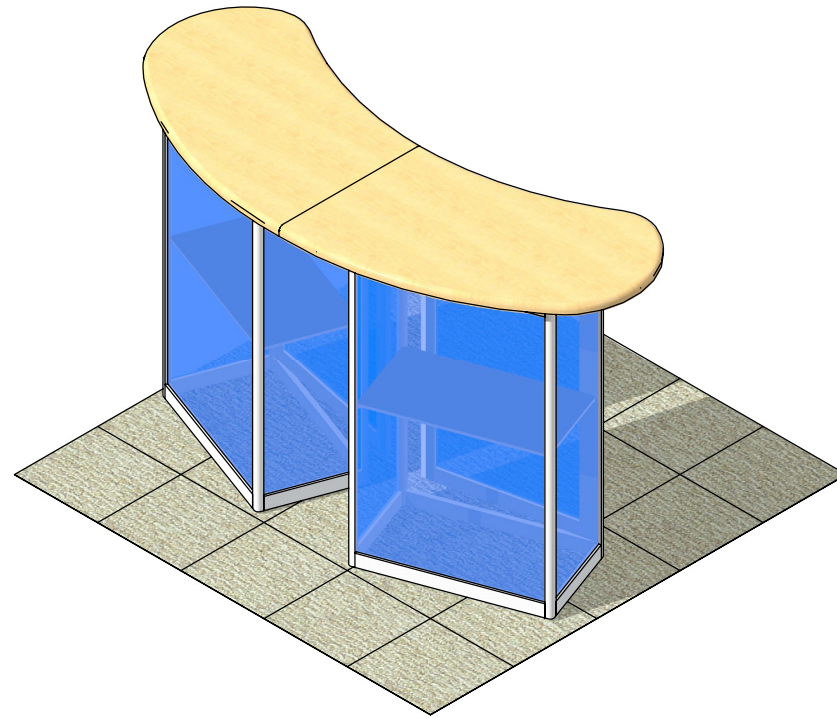

Step 1.
Attach the cabinet front (VC-02) and back (VC-03) using the VC-01s. See attachment detail below. Be sure to only turn locks half a turn as not to strip them.

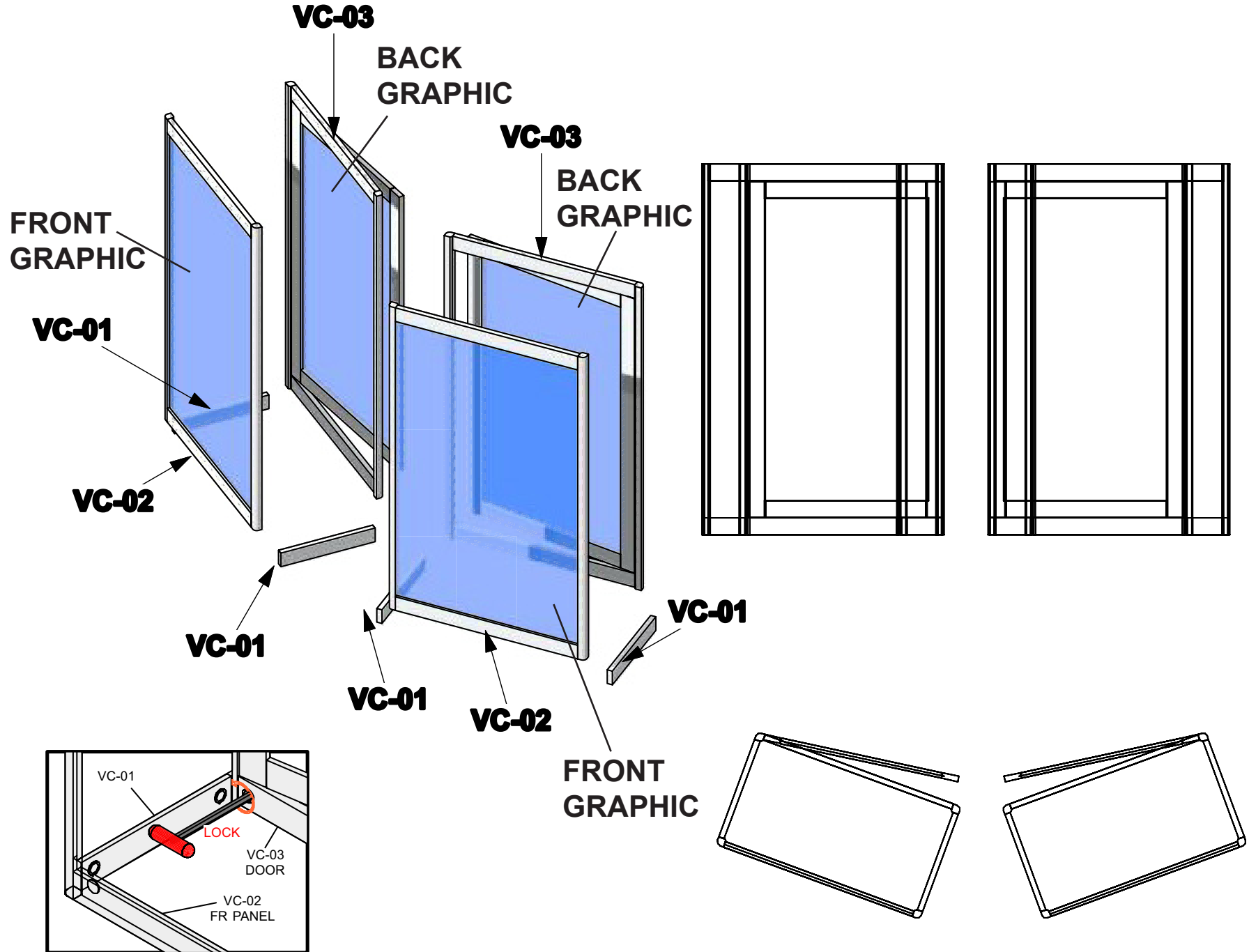

Step 2.

Slide the side graphics into the VC-01s and secure in place by securing a VC-01 over the top in the graphic. Insert shelf supports using detail below and gently place internal shelf on the supports.

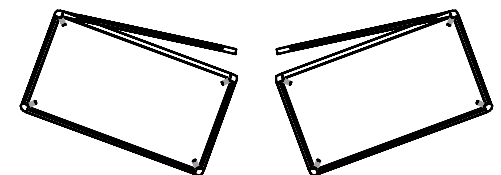
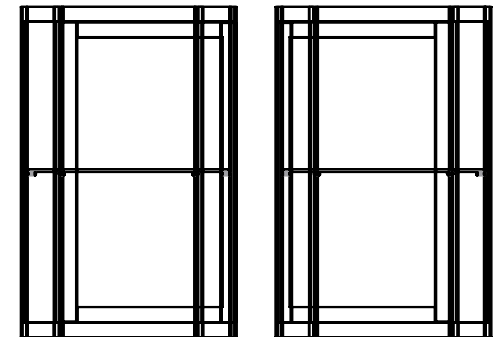
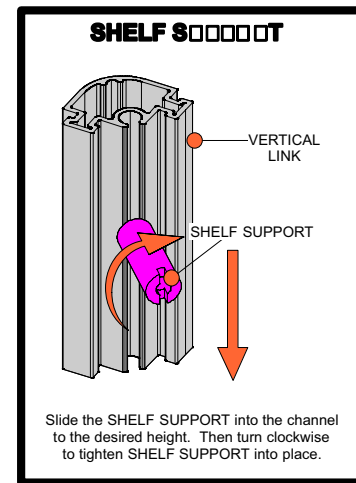
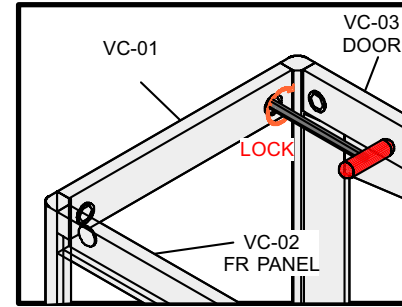
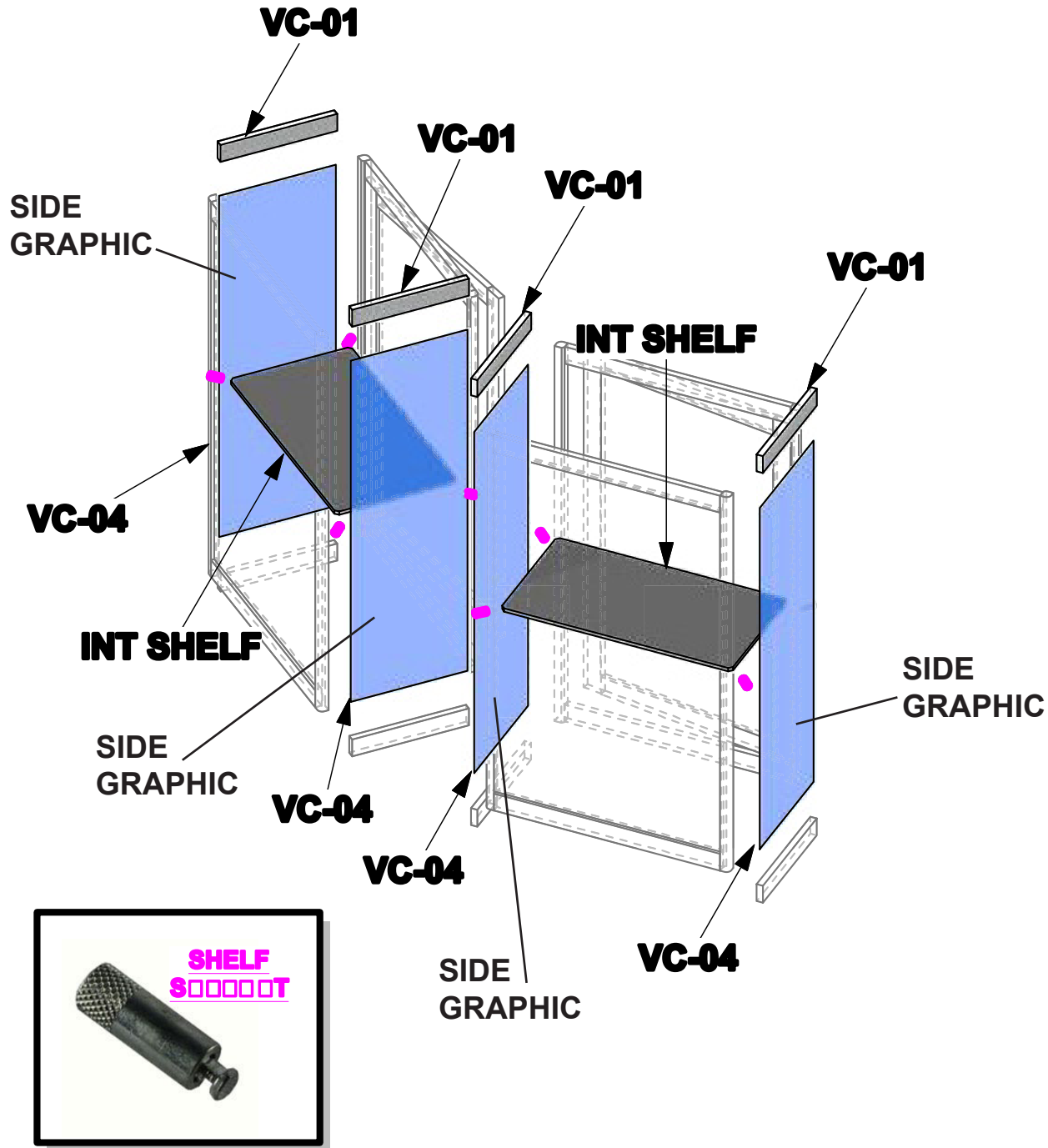

Step 3.
Attach completed countertop to cabinet base using
attachment detail.

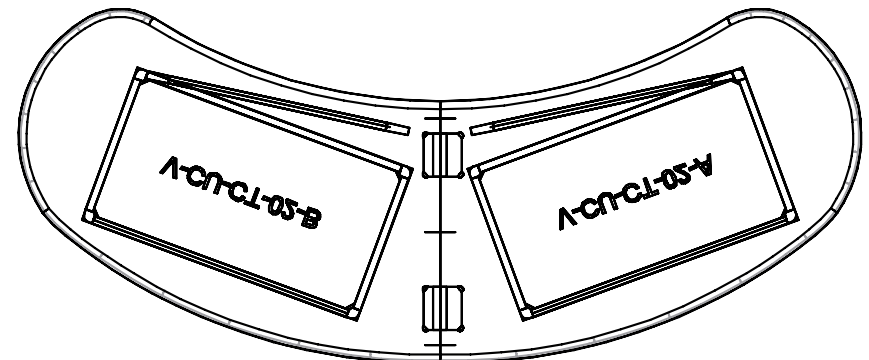
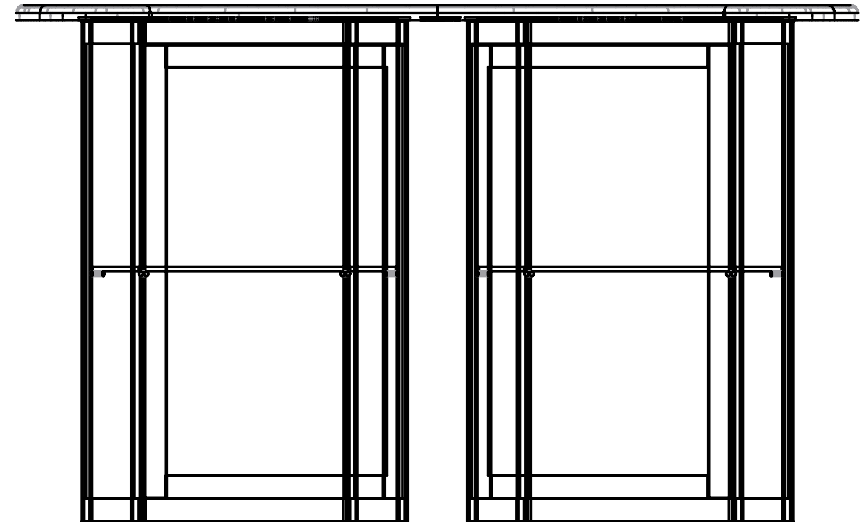
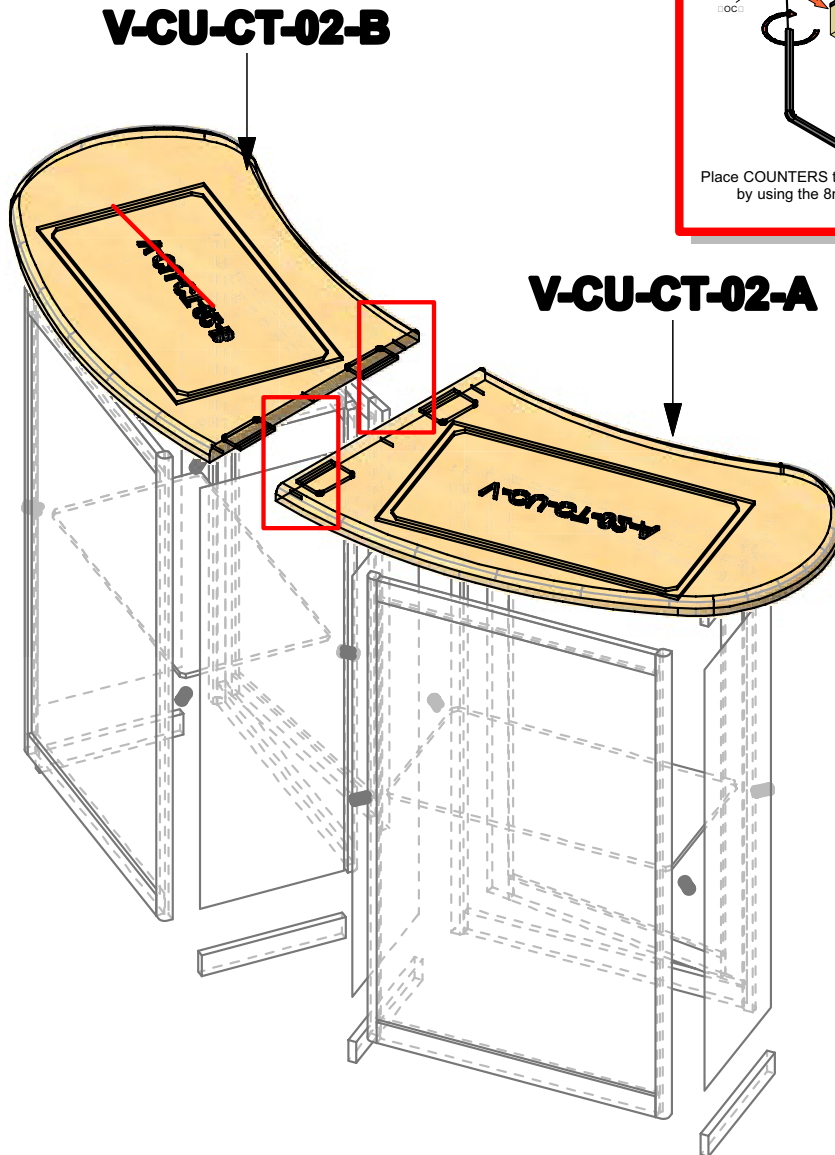
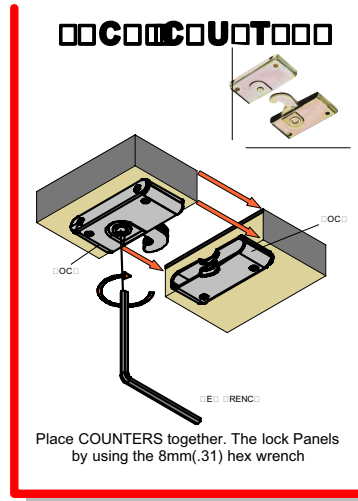

Linear Counters



X-Leg Counter



V-Leg Counter



Tusk Leg Counter



Oval Counter

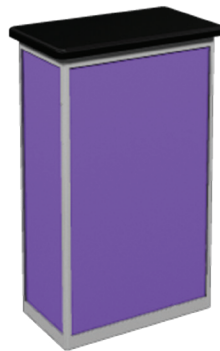

Counter - Rectangle



Straight Leg Counter



Double Reception Counter