

# Metis

## OR-K-MT1

Orbital Express Truss™ features over 40 professionally designed “off-the-shelf” kits for a variety of booth sizes and configurations. Each kit comes complete with all the parts, fixtures and fittings you need to create a successful exhibit, including (depending on the kit) low voltage spotlights and adjustable tabletops. A benefit to this versatile system is that it enables you to reconfigure kits in multiple ways and combinations using the same parts. Orbital Express Truss can also be easily customized!

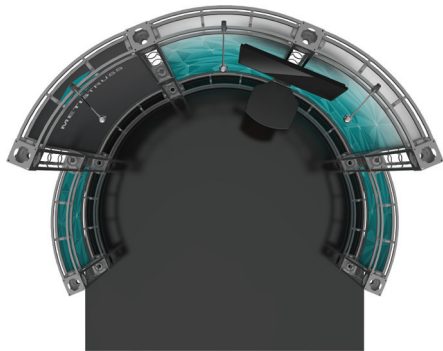
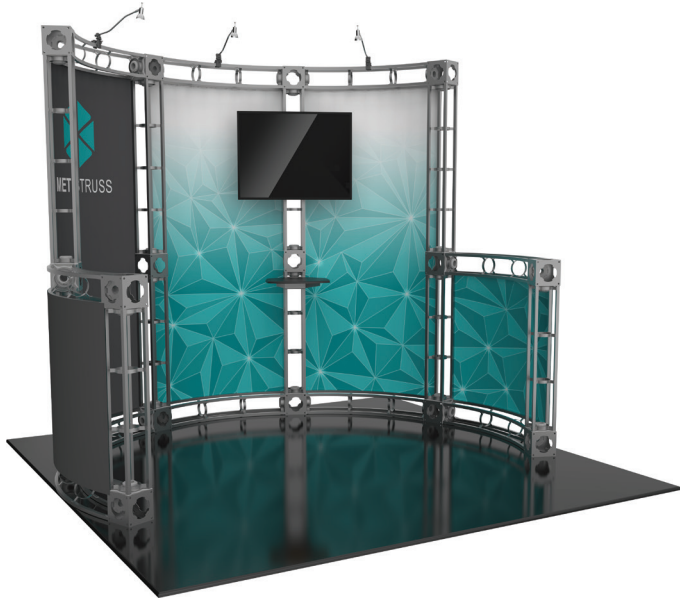

We are continually improving and modifying our product range and reserve the right to vary the specifications without prior notice. All dimensions and weights quoted are approximate and we accept no responsibility for variance. E&OE. See Graphic Templates for graphic bleed specifications.

## features and benefits:

- Kit includes:
  - 16 x 6-way junction boxes
  - 6 x 36" straight truss lengths
  - 4 x 46" straight truss lengths
  - 10 x 45° curved truss length
  - 1 x full set of quicklock connectors
  - 1 x adjustable tabletop
  - 1 x LCD monitor mount
  - 3 x 50 watt spotlights
  - 1 x OCF2 molded case
- 10' x 10' kit size
- Custom appearance
- Toolless assembly
- Simple twist and lock design
- 5 year warranty against manufacturer defects

## dimensions:

### Hardware:

Fits in a 10' x 10' space

### Shipping:

1 OCF2 case:  
51"l x 51"w x 24"h  
1295.4mm(l) x 1295.4mm(w) x 609.6mm(h)

Approximate weight:  
332 lbs / 151 kgs

### Graphics:

Total finished size:  
Panels MT1 & MT5: 43"w x 37.75"h

Panels MT2, MT3 & MT4: 43"w x 90"h

\*All dimensions available in millimeters  
Please be sure to include a 2" bleed around perimeter.

Refer to related graphic template for specific information on sizes and bleeds. Dye-sublimated graphic require different bleed than UV.

Visit [exhibitors-handbook.com/graphic-templates](http://exhibitors-handbook.com/graphic-templates)

## additional information:

Graphic materials: Dye sublimated or UV panels

Lumina 1, 50 watt spotlight

Monitor mount holds 13"-39"LCD,  
maximum weight = 50 lbs / 22.68 kgs

\*Kit does not include monitor

Tabletop color options: (if applicable)



METIS PIECE COUNT:



OR-J-3  
16



OR-J-DBL  
0



OR-24-2  
0



OR-30-2  
0

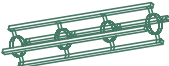

OR-36-2  
6

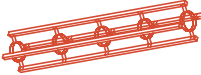

OR-46-2  
4



OR-45-CV-3  
10



OR-90-CV-2  
0



OR-B90  
0

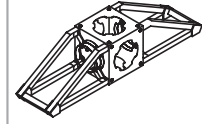

OR-B90A  
0

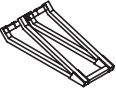

OR-B45  
0



OR-TOOL-B  
1



OR-QL-T2J  
40



OR-QL-T2T  
0



OR-UC-QL  
0



OR-STG  
0



OR-LCD1-B  
1

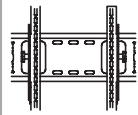

OR-LCD2-B  
0

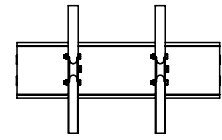

OR-LCD3-B  
0



SPOTLIGHT  
3



OR-TBL  
1



OR-TBL2-L  
0



OR-TBL2-R  
0



OR-IS-24 0



OR-IS-36 0



OR-IS-46 0



OR-IS-48 0



OR-CIS-90  
0



OR-SE-IS-90  
0



OR-CIS-45  
0

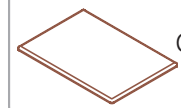

OR-ATL-CNTR  
0

METIS TABLETOP ACCESSORY PIECE COUNT:

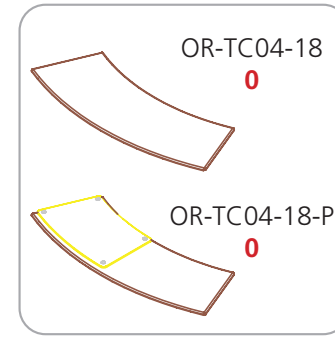
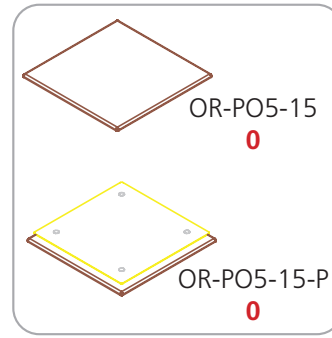
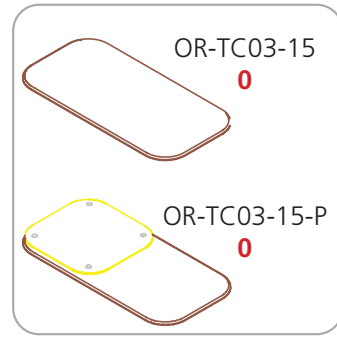
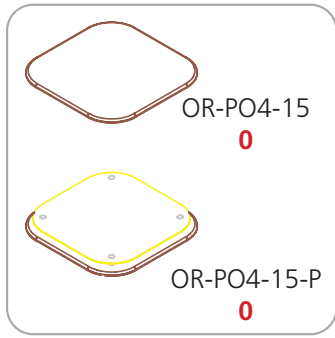
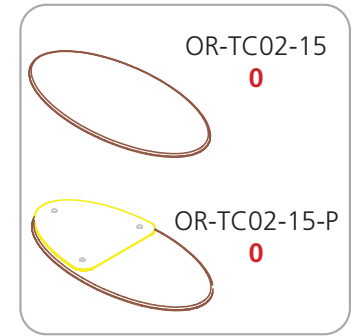
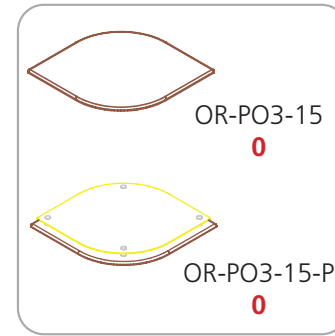
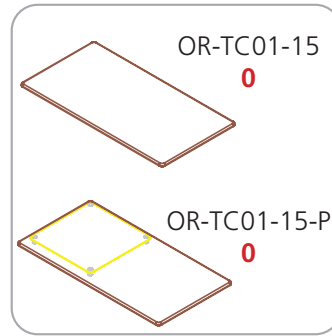
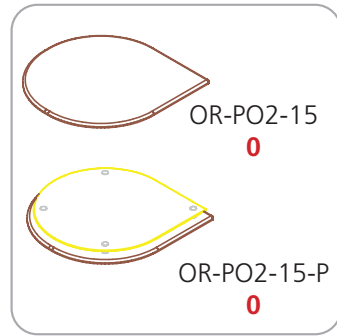
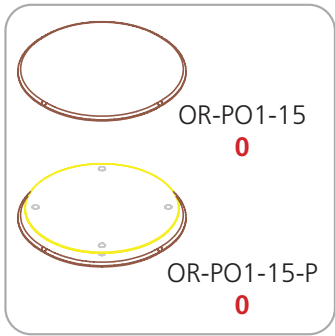

METIS CASE COUNT:

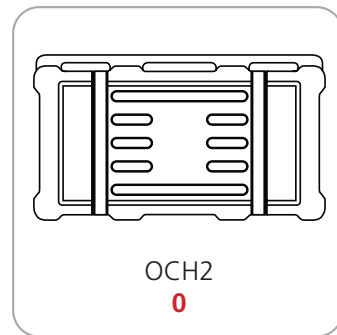
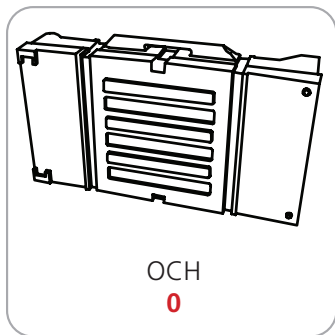
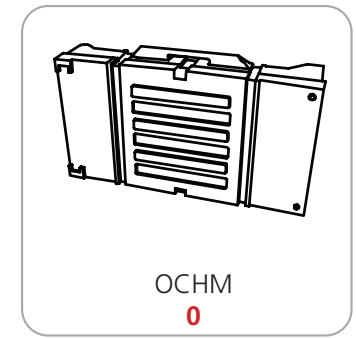
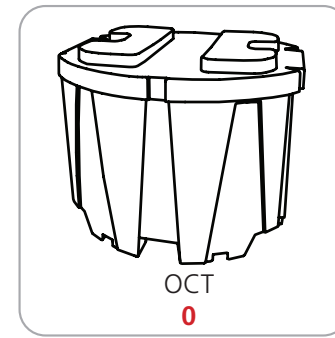
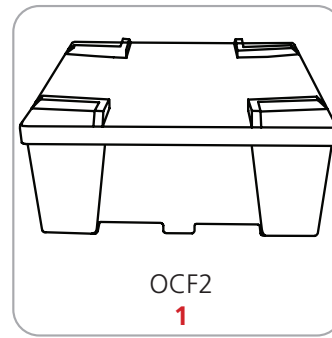
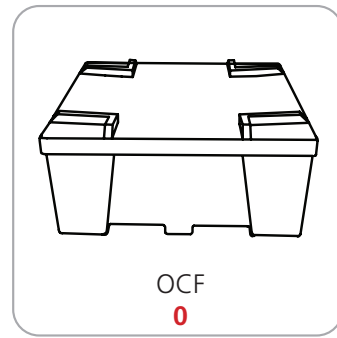
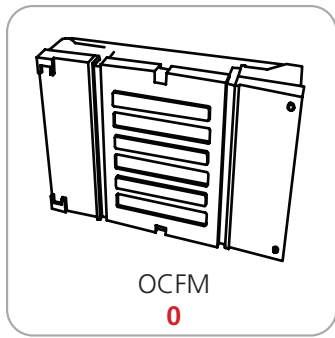

**METIS GRAPHIC SPECS:  
AVAILABLE GRAPHICS – UV & DYE SUBLIMATION**

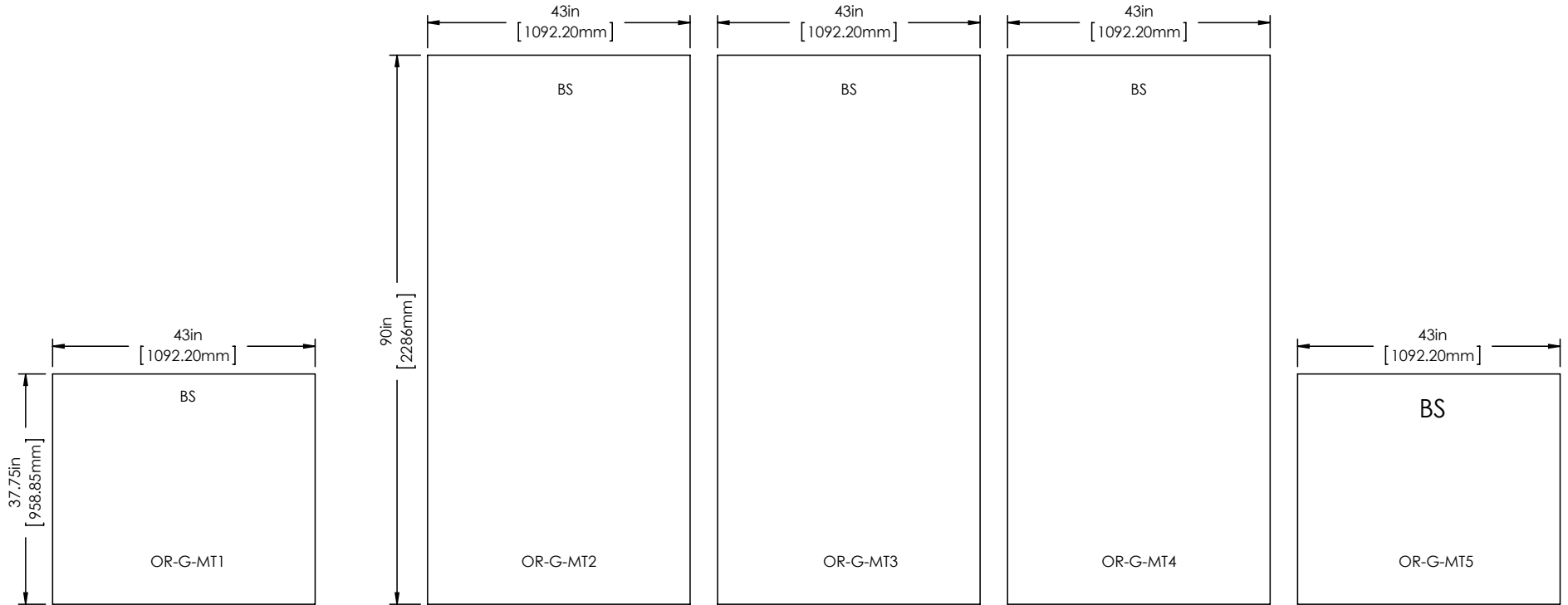

**Acceptable File formats:**

Illustrator CC or below  
Photoshop CC or below  
Art time will be charged if files need to be fixed or altered to meet guidelines. When sending files please be sure to include all support art (fonts, linked images, etc.)

**Font Specifications:**

Fonts must be converted to outlines.

**Bleeds:**

All orbital truss graphics require specific bleeds. The sizes listed above represent the finished graphic size. Please keep all logos, type and critical information at least 1" in from each edge of the finished graphic.

**Dye Sublimation:** 2" bleed around the perimeter.

**UV:** 1/2" bleed around the perimeter.

**Color:**

All files are printed as CMYK format. All critical Pantone colors need to be called out in the file or specified on the order as Coated or Uncoated swatches.

**Resolution:**

All raster files (either print files or linked files) must be at 100-120 pixels per inch at 100%

**Finishing Details:**

When graphics are notched, a 7/8" square is cut in the appropriate location.

**FS:** Graphics mounted to front of truss system

**BS:** Graphics mounted to back of truss system

Dye Sublimation graphics are attached to truss with velcro. UV panels are attached to truss with magnet.

**To ensure quality, please note:**

Each graphic has a specific code or number located on the graphic. The electronic print files provided must be named accordingly. Using this coding system will allow us to preflight and prepare your files for print more efficiently. **If you fail to provide your graphic files in this format, additional charges may be necessary to complete your printed materials.**

METIS GRAPHIC LAYOUT:

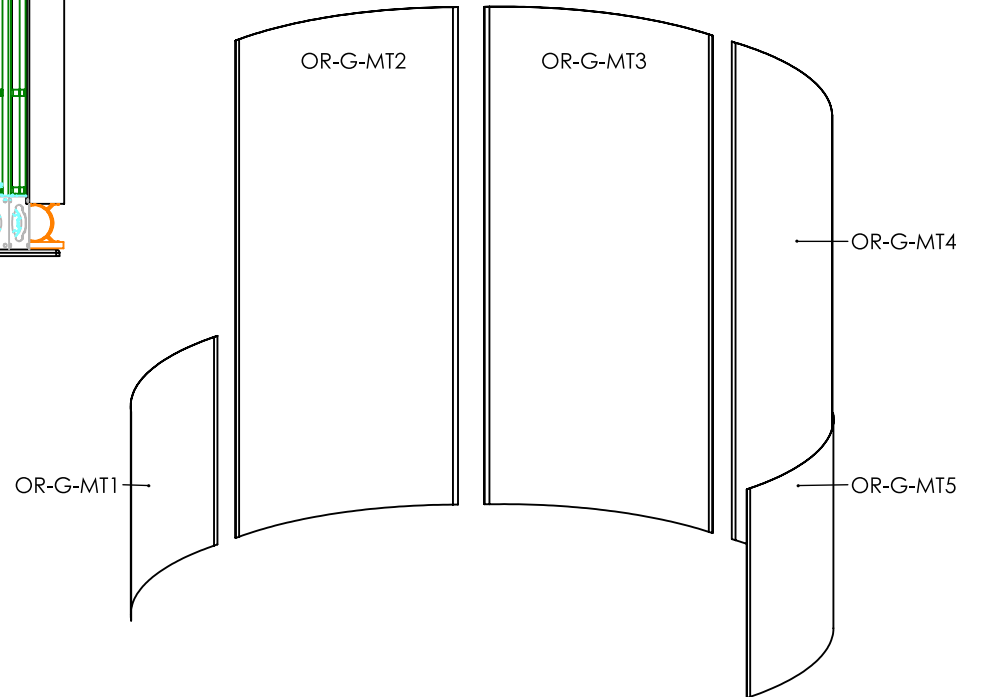
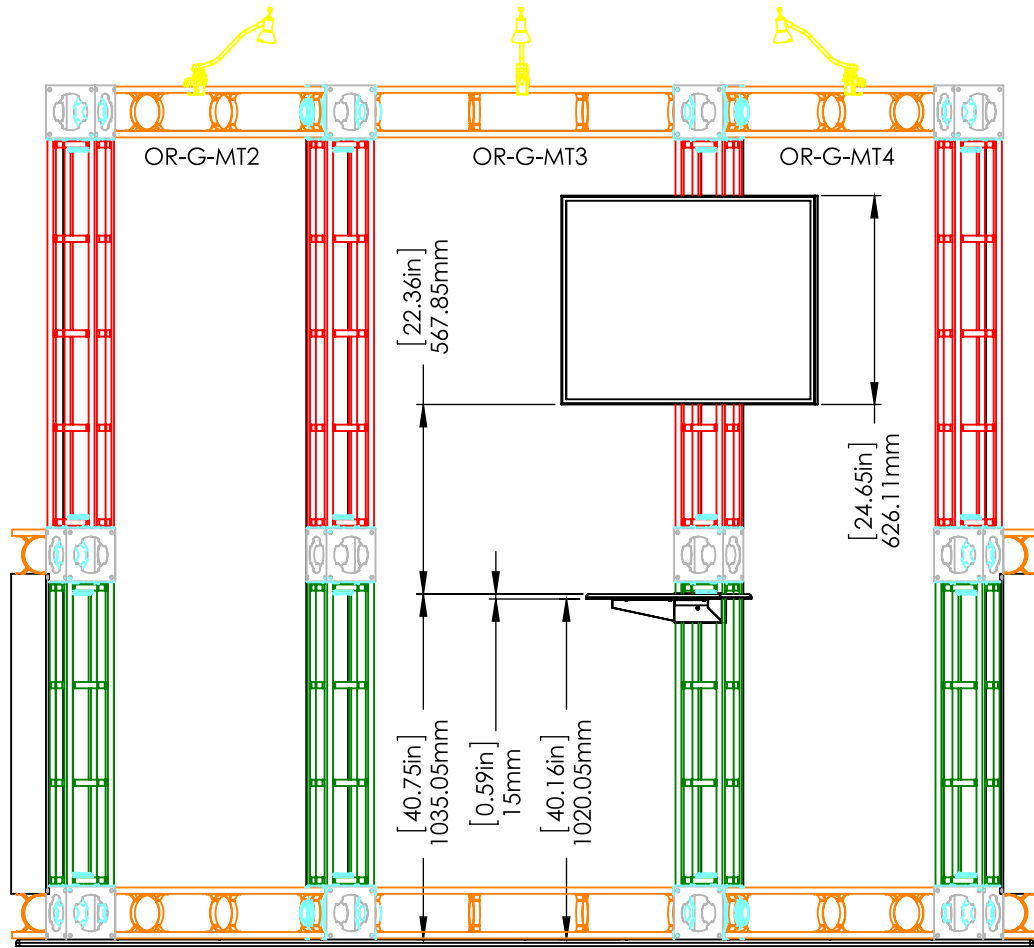

METIS FLOOR PLAN:

SCALE REF = 5ft

10'd x 10'w Inline

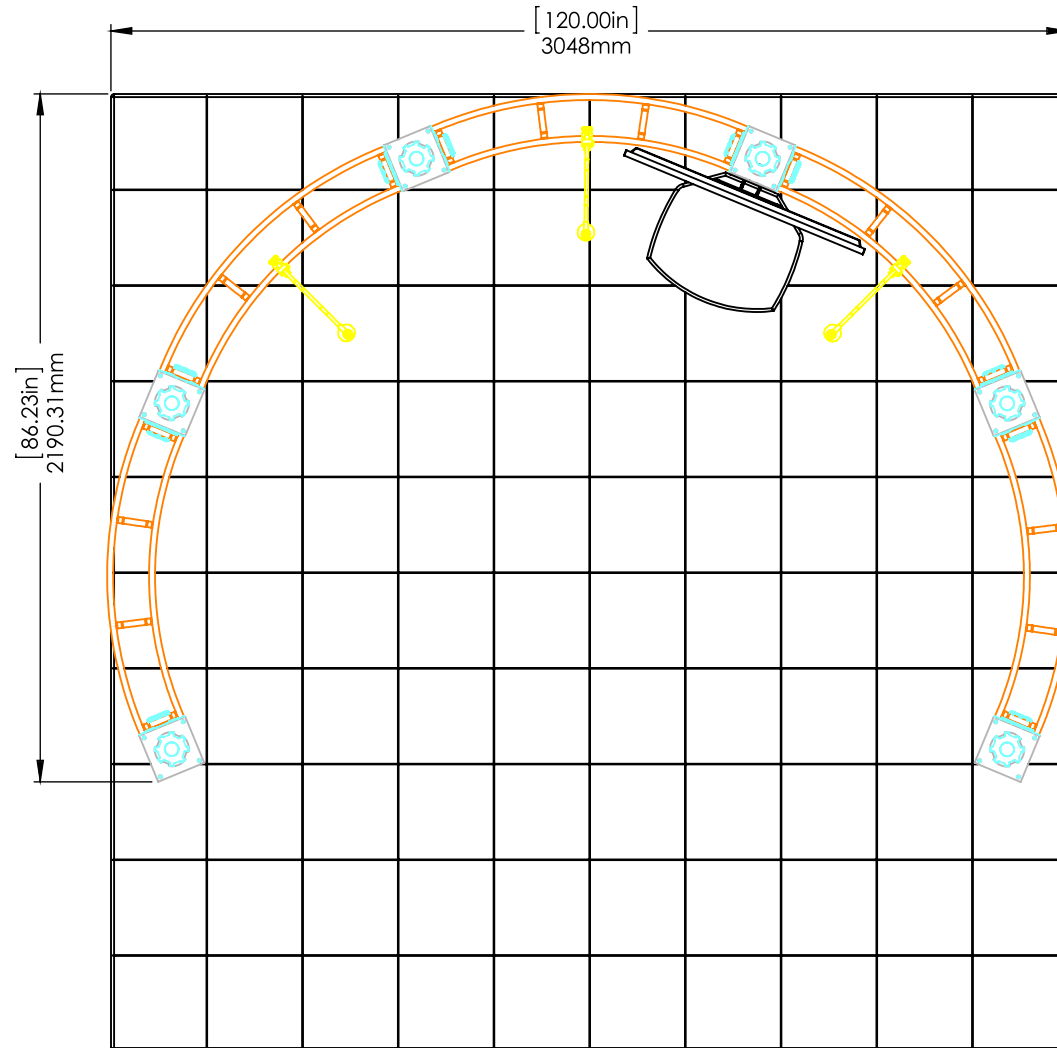

METIS COLOR CODED PARTS:

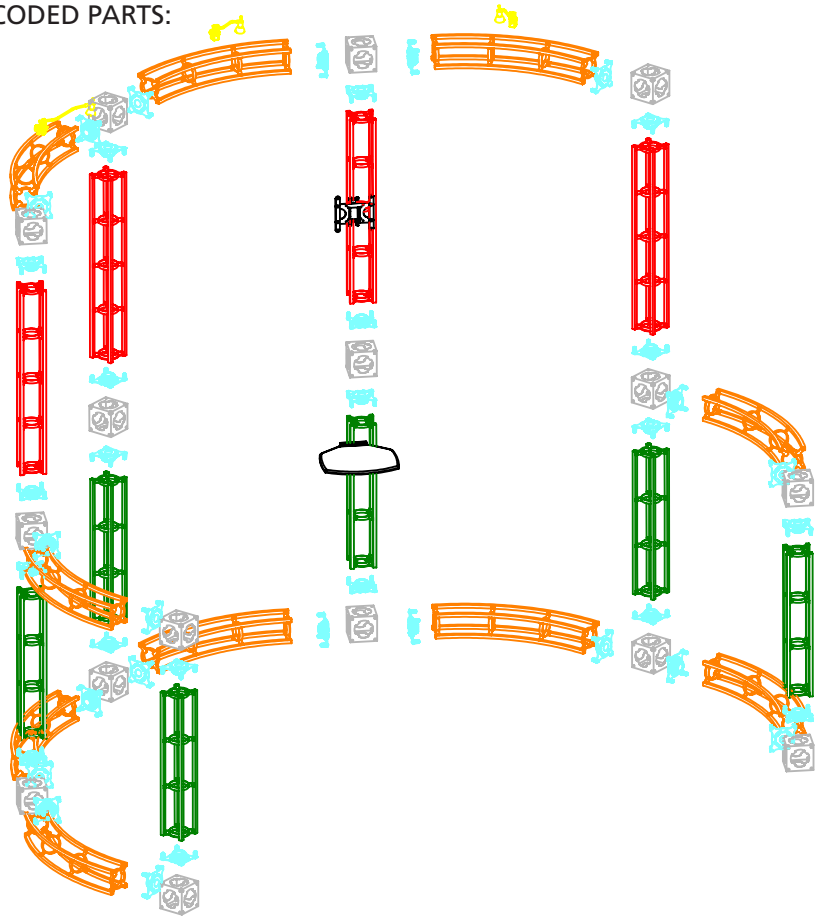

Parts exploded

